

# SKIMMER

BY  
WELTICO

63681  
le 13/12/2018

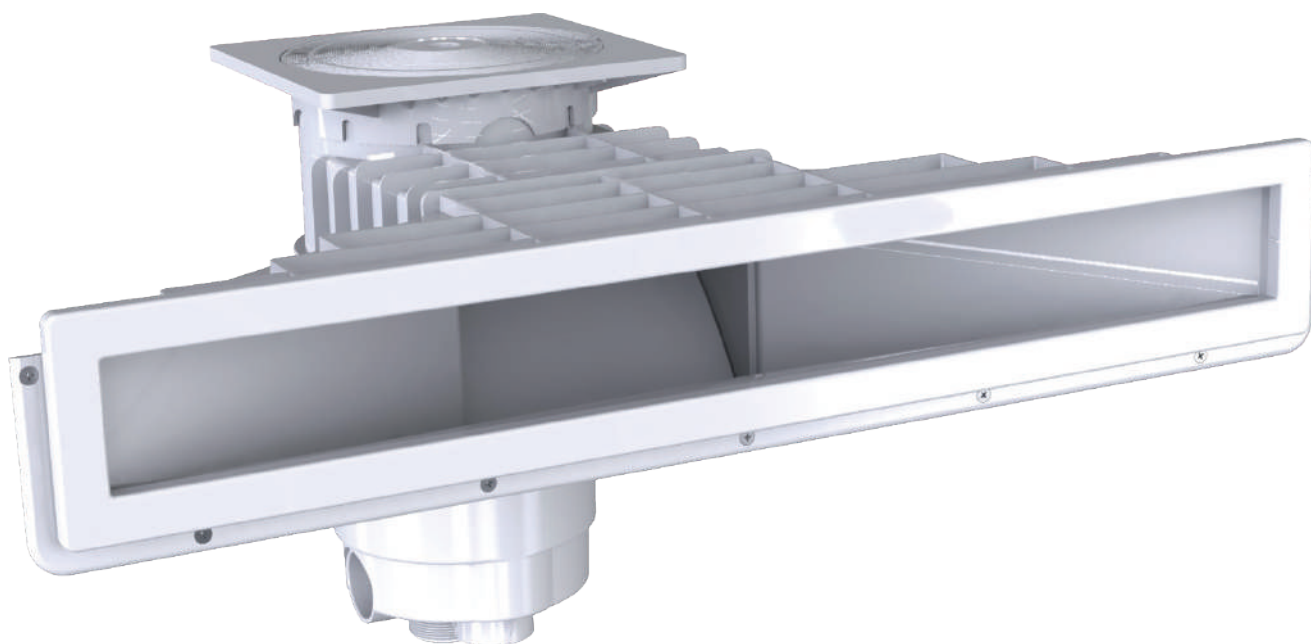

FR ... 2  
EN ... 7  
ES ... 12  
IT ..... 17  
DE ... 22  
NL ... 27  
PT .... 32

Made in France  
2 years warranty

Photos non contractuelles.  
Non-contract photo.

*weltico*  
by *acis*

15 rue des Marais  
44310 St Philbert de Gd Lieu  
Tel : +33 (0)2 40 59 95 35  
technique.acis@acis-france.com

## NOTICE DE MONTAGE SKIMMER A800

Nous vous remercions d'avoir choisi un matériel WELTICO et nous vous invitons à lire attentivement cette notice vous permettant d'en obtenir toute satisfaction.

- L'installation de ce SKIMMER nécessite l'intervention de personnes qualifiées.



**IMPORTANT** : cette notice contient des informations de premières importances sur les mesures de sécurité à adopter au moment de l'installation et de la mise en service. Il est par conséquent indispensable que l'installateur et l'utilisateur lisent attentivement ces instructions avant de commencer le montage.

Cette notice est également disponible au format PDF et EPUB sur [www.weltico.com](http://www.weltico.com) rubrique SKIMMER.

### À LA RÉCEPTION DU MATÉRIEL

Vous devez avoir reçu un ensemble de 2 colis :

- Un colis contenant le meurtrière et ses accessoires.
- Un colis contenant la partie SKIMMER et ses accessoires.

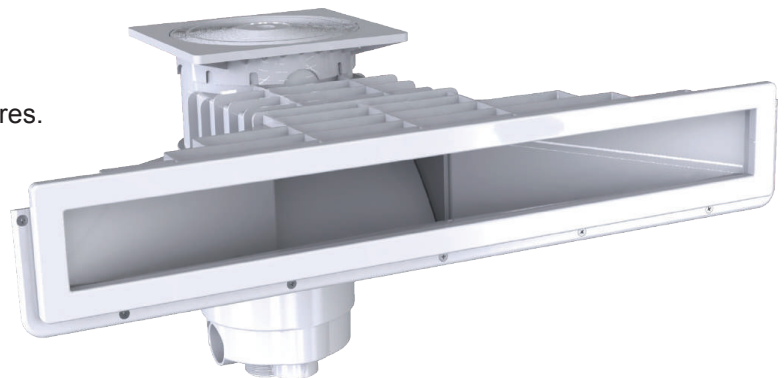

### SPÉCIFICATIONS TECHNIQUES :

VERSION : PANNEAU / LINER / BETON / COQUE

- Fabriqués en ABS
- Trop plein Ø 50mm extérieur
- Sorties : -Ø50mm intérieur (x2)  
-1"1/2 intérieur ou 2" extérieur

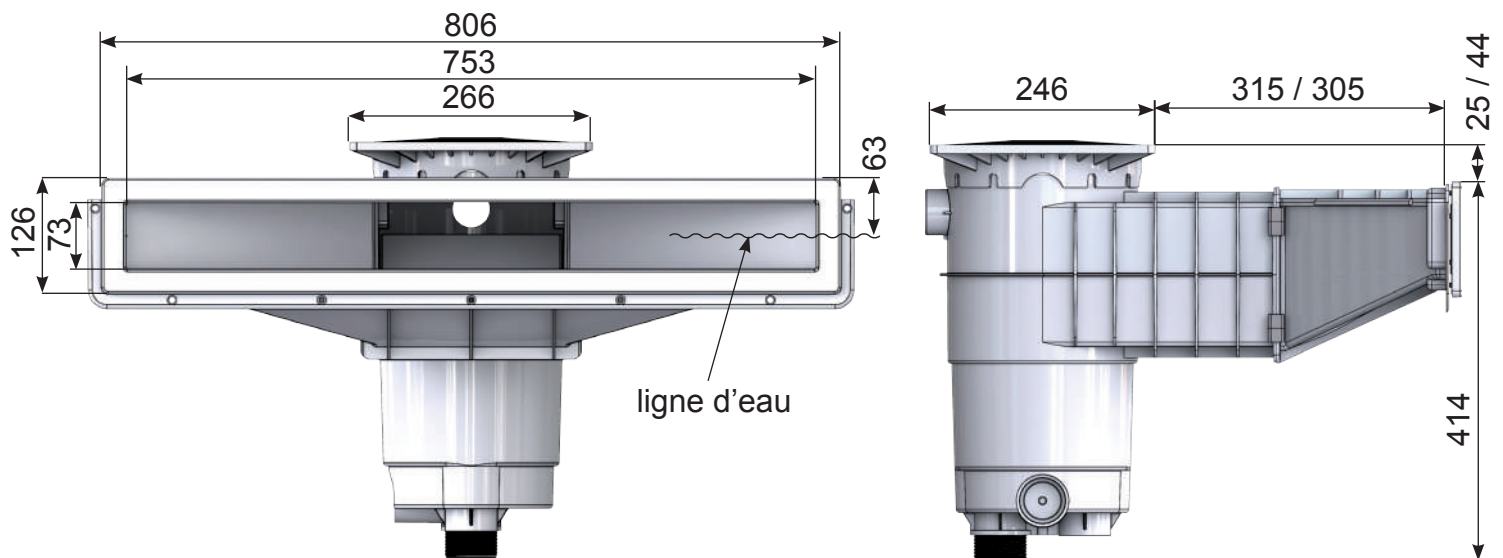

## ASSEMBLAGE

Les deux parties peuvent être assemblées avant ou après la mise en place sur la paroi.

 **ATTENTION** : Une fois les deux parties collées avec la colle fournie, il est pratiquement impossible de les séparer au bout d'une 1/2 heure.

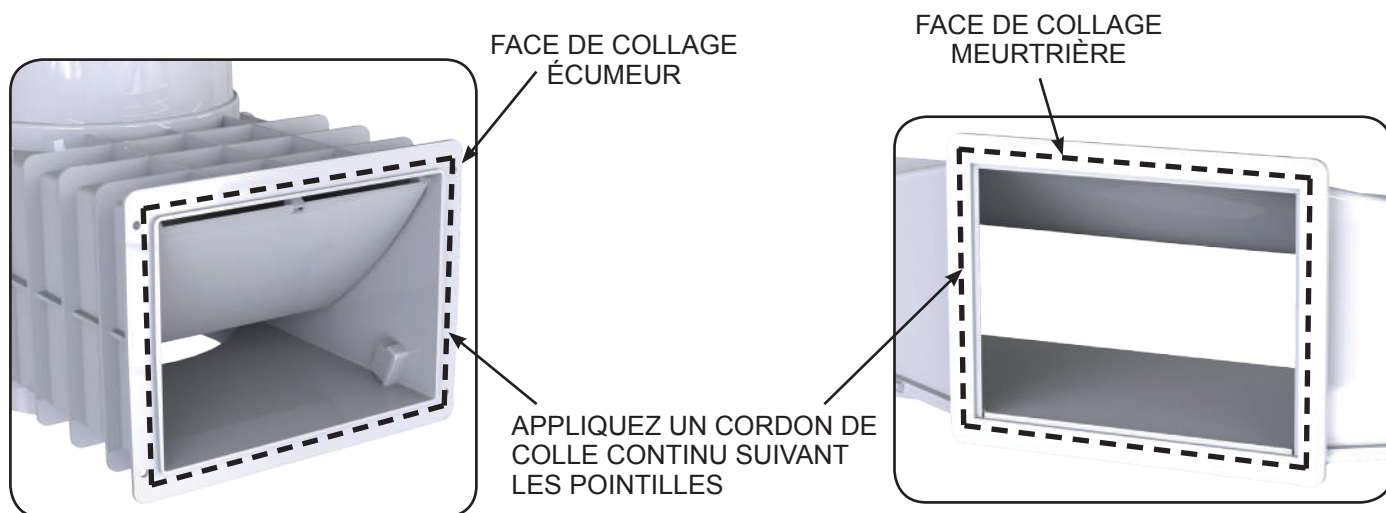
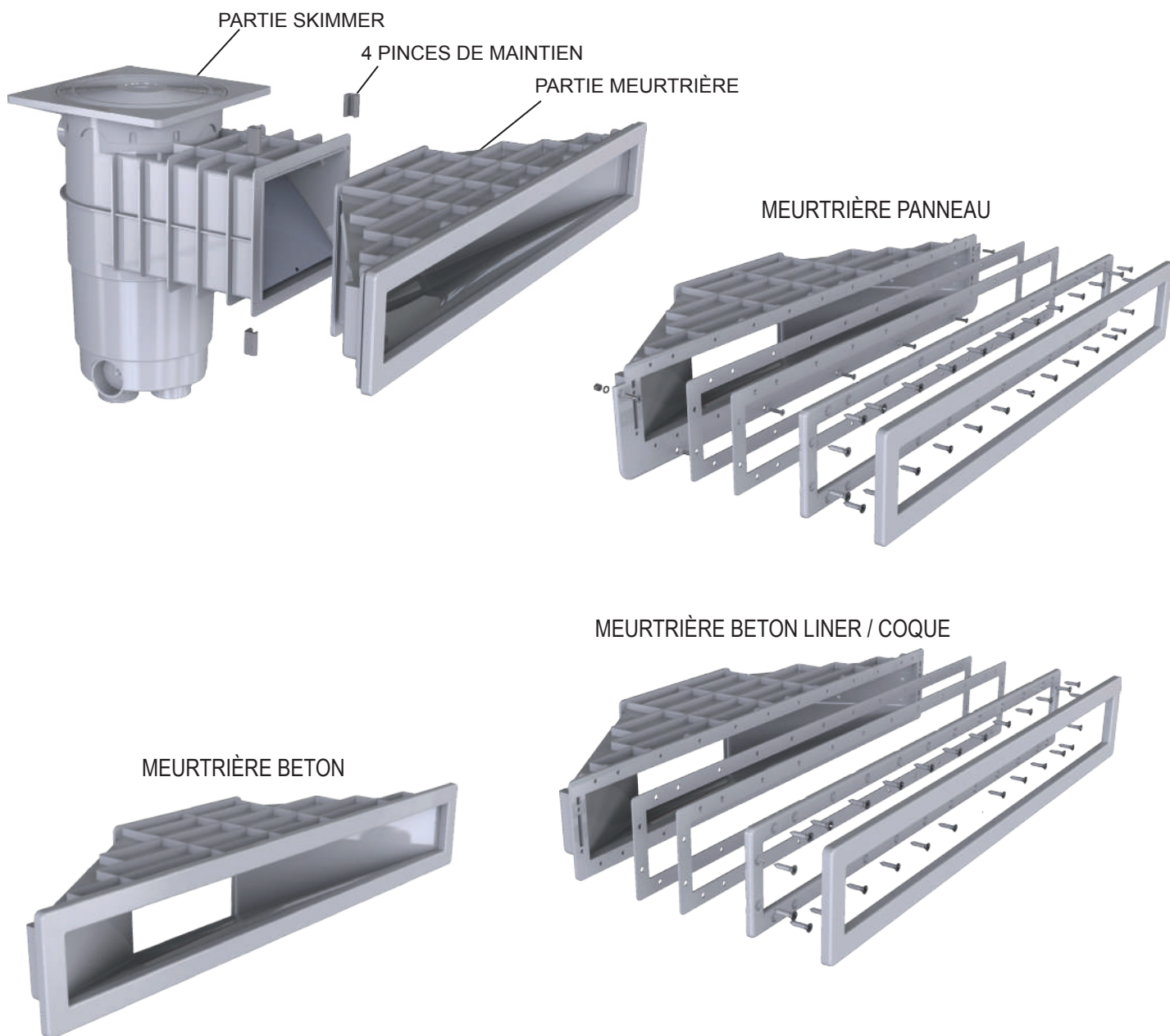

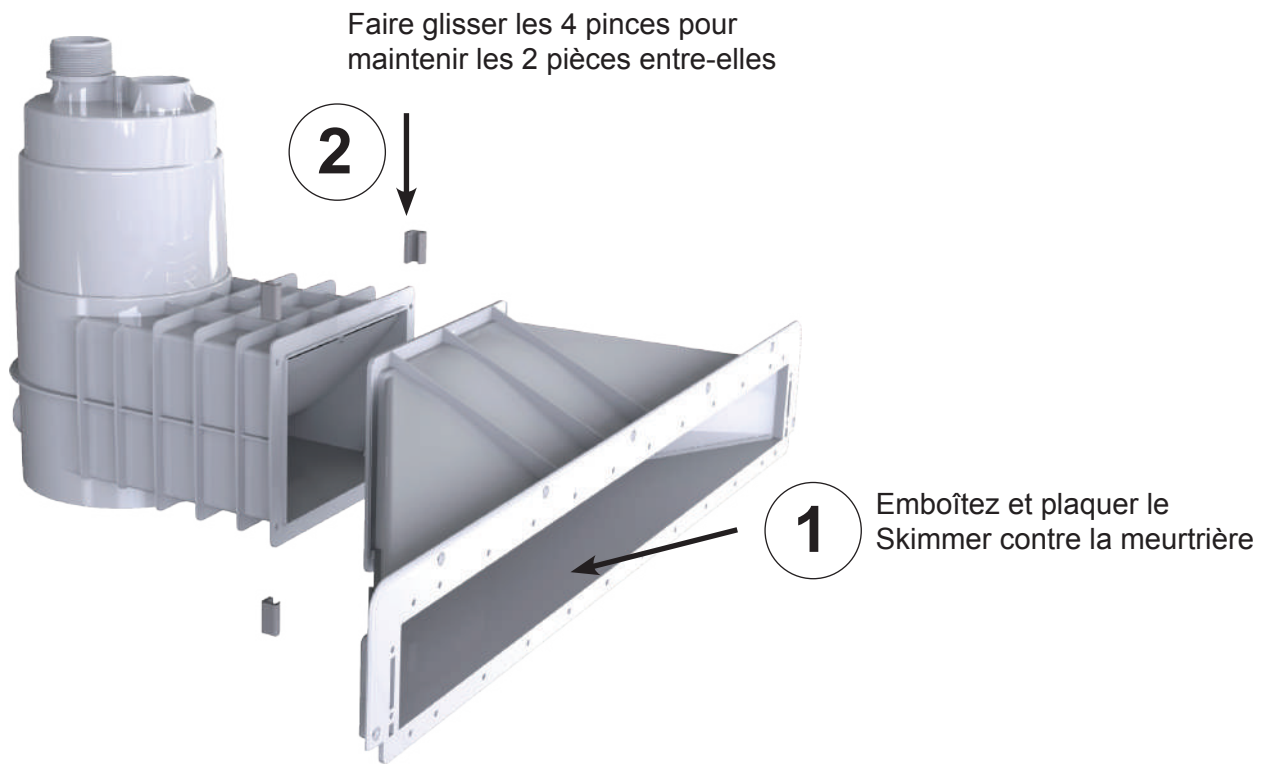

### MISE EN PLACE SUR LA PAROI PANNEAU

La version panneau demande une découpe particulière pour sa fixation.



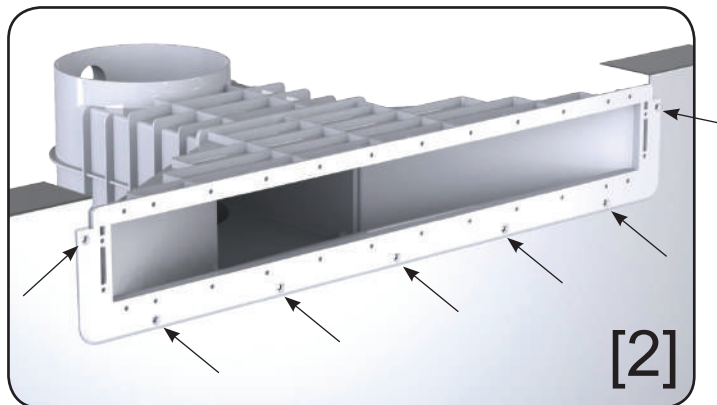

Mettre l'ensemble ou la meurtrière en position sur la paroi comme ci-dessus.  
Contre-percez aux endroits fléchés pour les passages des vis. Boulonner avec les vis fournies.

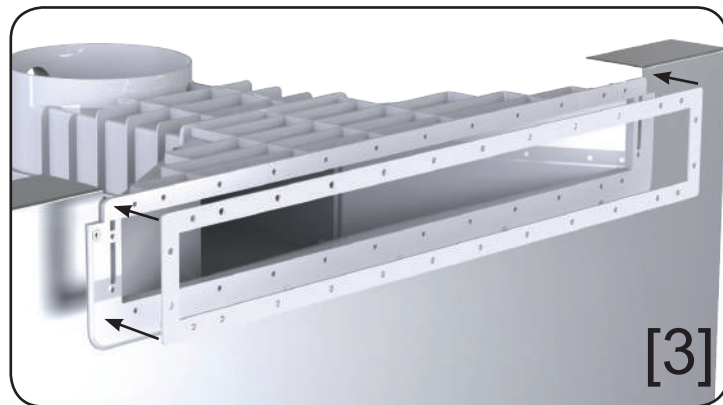

Posez un joint plat coté adhésif sur la meurtrière.

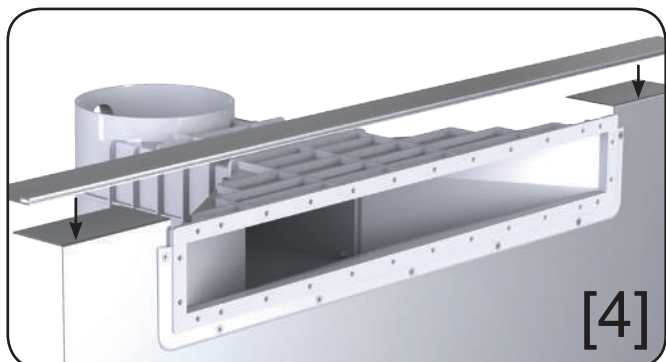

Fixez l'accroche liner sur le dessus de la paroi.  
Renforcez par une traversée métallique à fixer sur les bossages prévus.

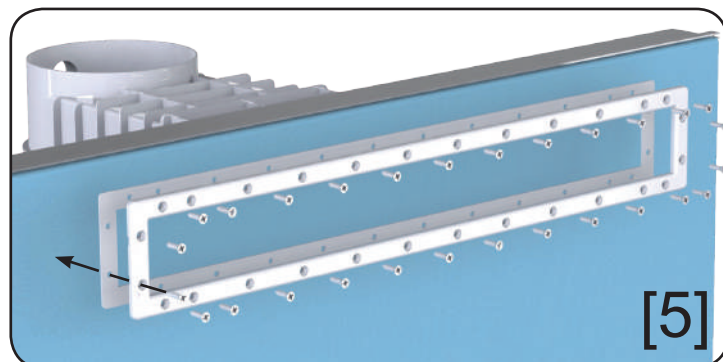

Une fois le liner posé, mettre le deuxième joint plat coté adhésif sur la bride. Positionnez la bride sur le liner afin de faire correspondre les trous puis vissez toutes les vis.

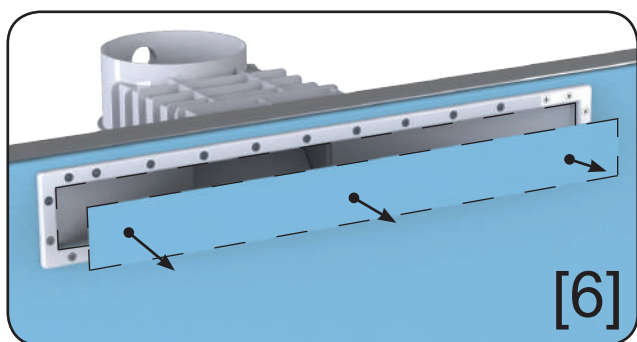

A l'aide d'un cutter, découpez le liner à l'intérieur de la bride. Enlevez la chute de liner.

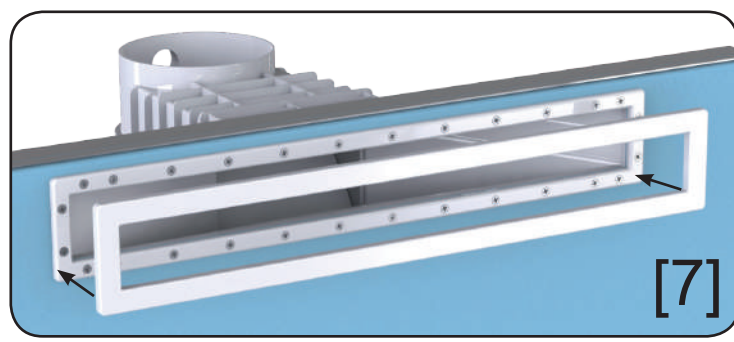

Clipsez le cache vis sur la bride

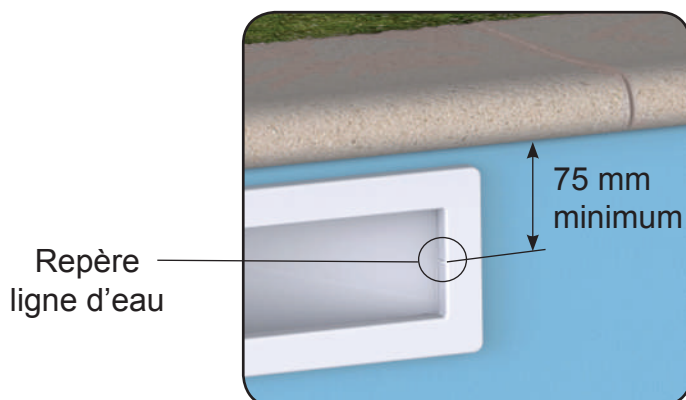



## MISE EN PLACE SUR LA PAROI BETON, BETON LINER OU COQUE

Les procédés de mise en place sont identiques aux modèles traditionnels.

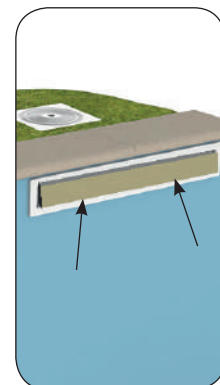
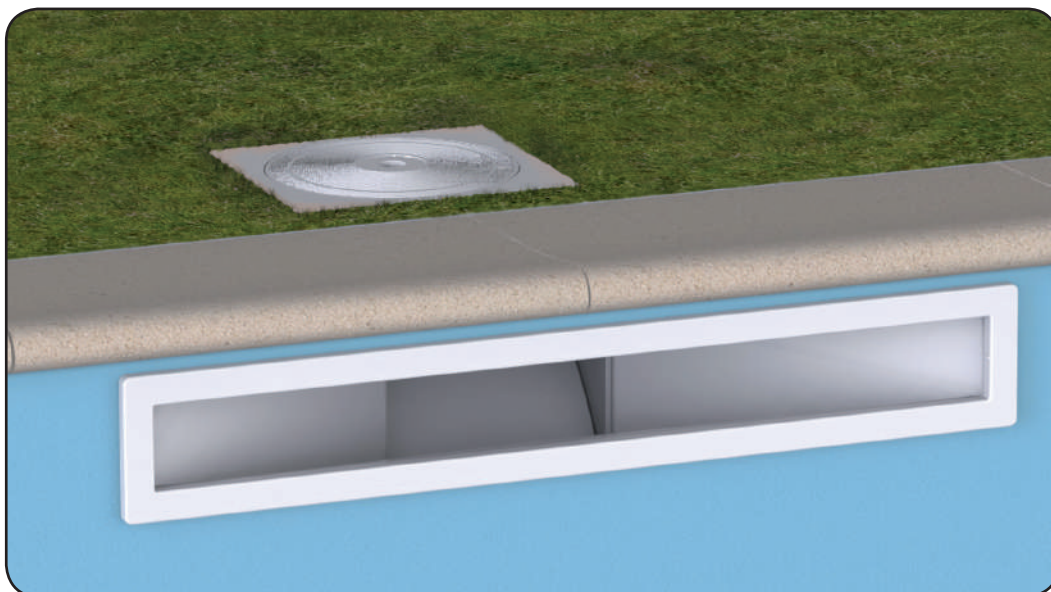

 Mettre en place le bloc de mousse avant le coulage du béton.

### PIÈCES DÉTACHÉES

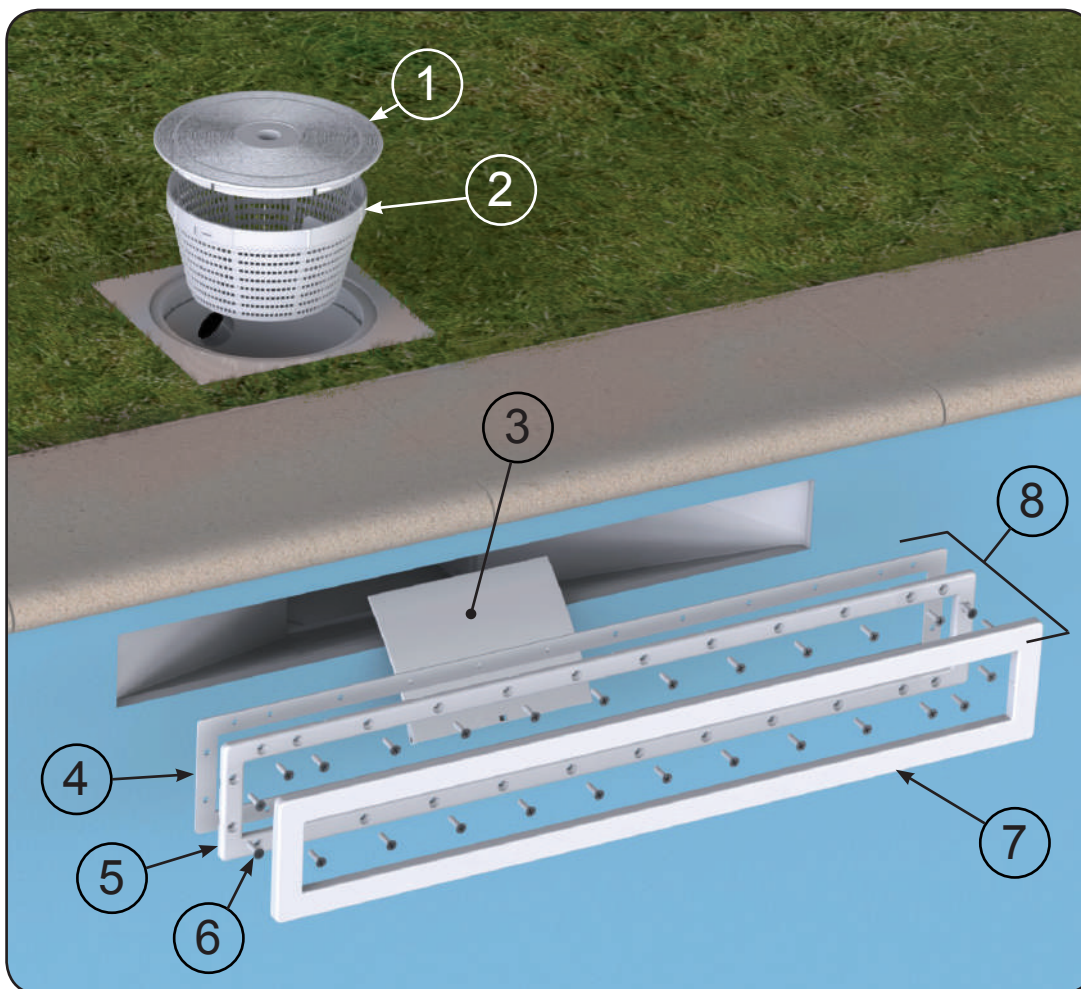

N°	LINER	BETON	COQUE
1	COUVERCLE	COUVERCLE	COUVERCLE
2	PANIER	PANIER	PANIER
3	VOLET	VOLET	VOLET
4	JOINT PLAT A800	-	JOINT PLAT A800
5	BRIDE A800	-	BRIDE A800
6	SACHET VIS LINER A800	-	SACHET VIS LINER A800
7	CACHE VIS A800	-	CACHE VIS A800
8	KIT LINER A800	-	KIT LINER A800

# INSTALLATION INSTRUCTIONS

## SKIMMER A800

We thank you for choosing WELTICO materials and we invite you to read these instructions to ensure your complete satisfaction.

- Installation of this Skimmer requires skilled people.



**IMPORTANT :** This manual contains information of great importance on the safety measures to be adopted at the time of installation and commissioning. It is therefore essential that the installer and user read these instructions carefully before beginning installation.

This manual is also available in PDF and EPUB on [www.weltico.com](http://www.weltico.com) - SKIMMER section.

### RECEIVING EQUIPMENT

You should have received a set of two packages:

- One package containing the input and accessories.
- One package containing the part and accessories.

### TECHNICAL SPECIFICATIONS:

#### VERSION: PANEL / LINER / CONCRETE / SHELL

- - Made of ABS
- - Overflow Ø50mm outside
- - Outings : -Ø50mm inside (x2)  
-1"1/2 inside or 2" outside

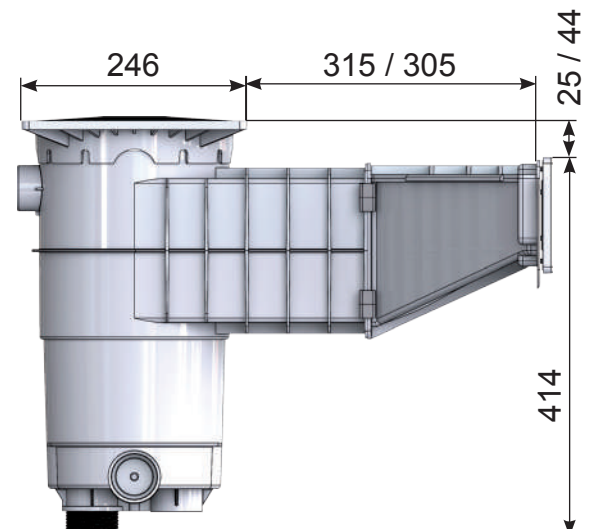
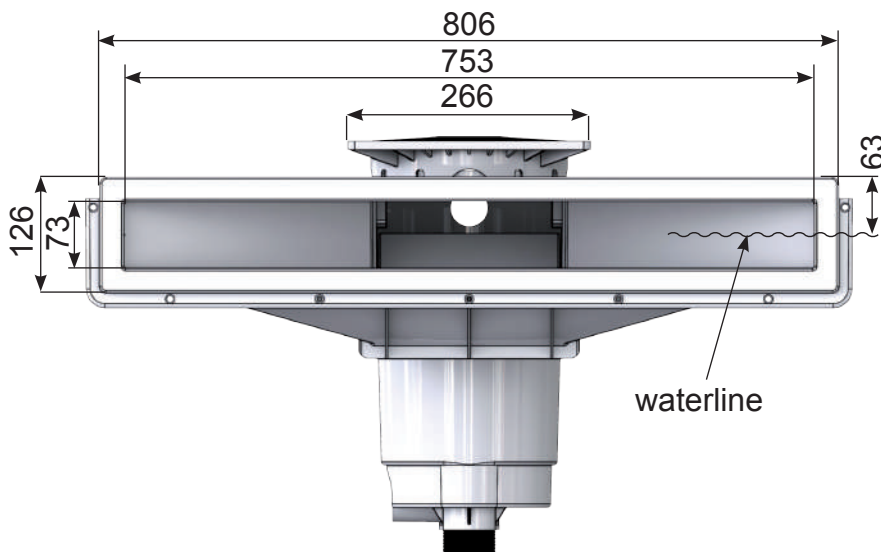
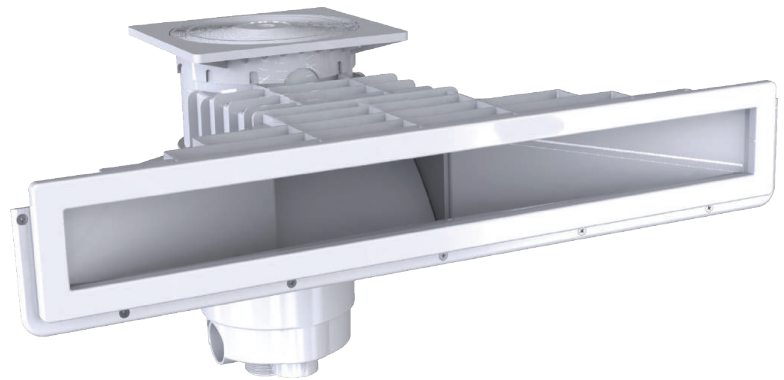

# ASSEMBLY

The two parts may be joined before or after placement on the wall.

**CAUTION:** Once the two parts are glued with the glue provided, it is virtually impossible to separate them after half an hour.

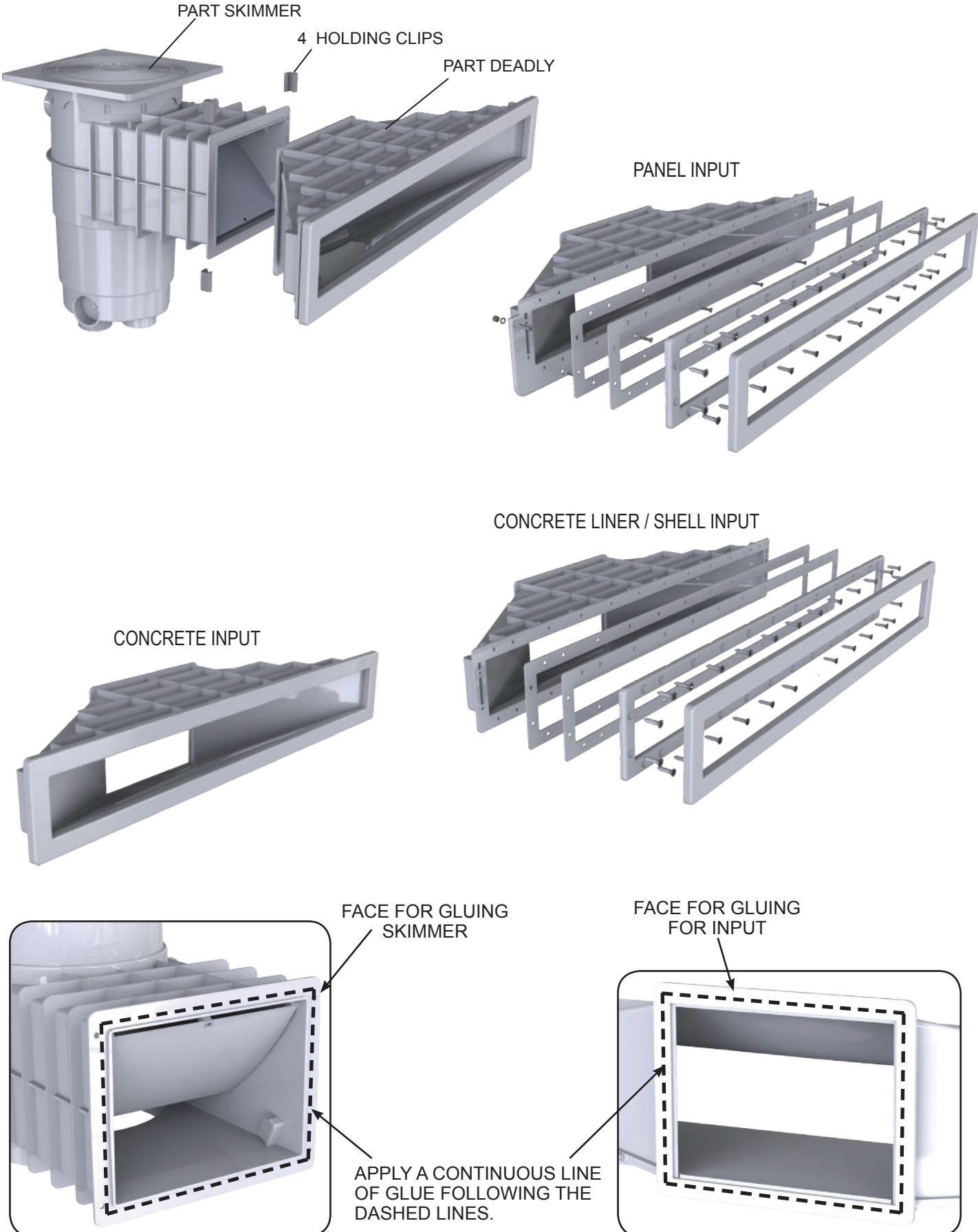



Slide the four clips to hold the two parts against each other.

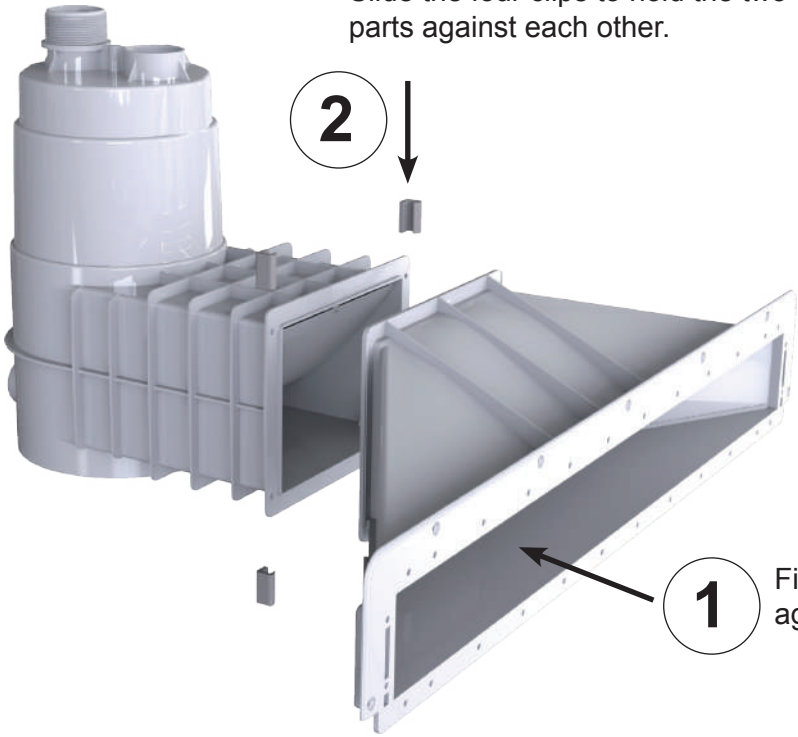

1 Fit and flatten the Skmmer against the input

**INSTALLATION ON PANEL WALL**

The panel version requires special cutting for its fixing.



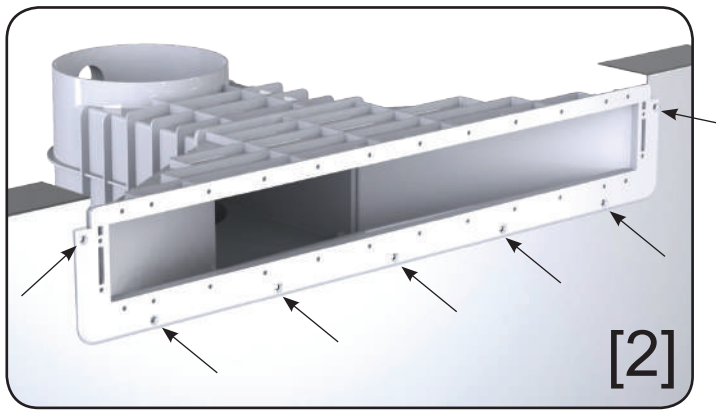

Put the assembly or the input in position on the wall as above.  
Pierce holes in the arrowed locations for the passage of screws. Bolt with the screws supplied.

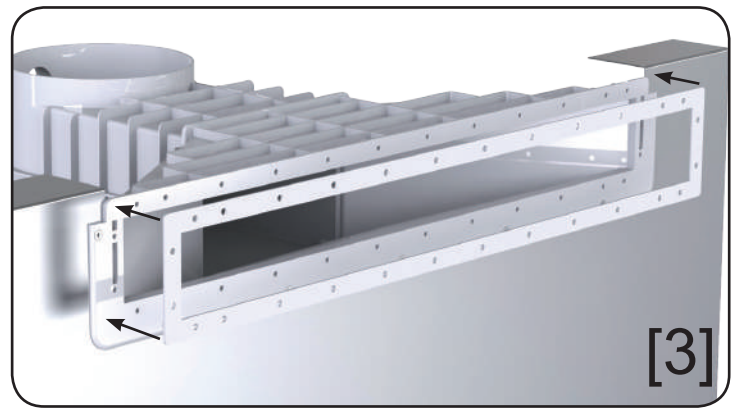

Fix a flat joint, adhesive side, to the input.

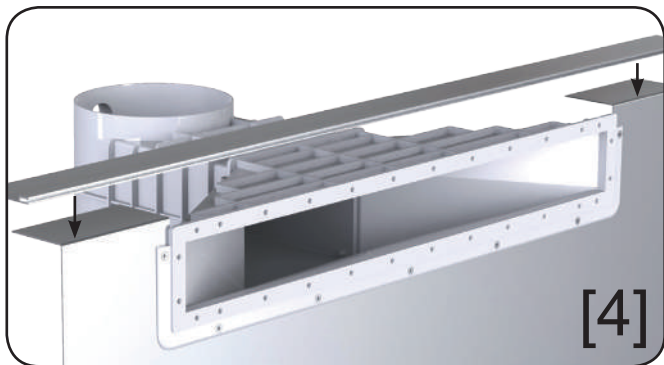

Attach the liner hook on top of the wall.  
Reinforce a metal bushing to be fixed on bosses provided.

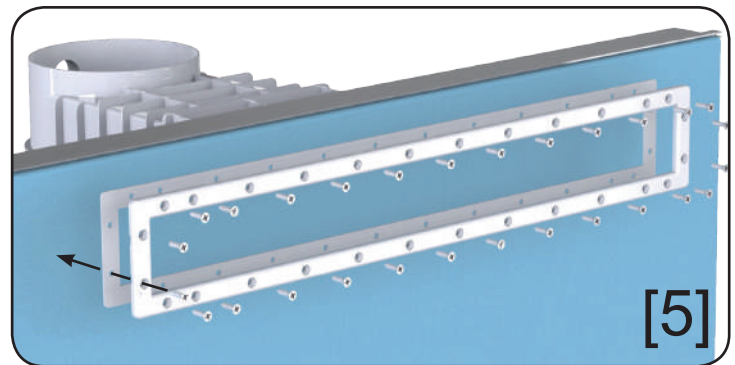

Once the liner is in position, place the second flat joint, adhesive side, on the flange. Position the flange of the liner to match the holes and tighten all the screws.

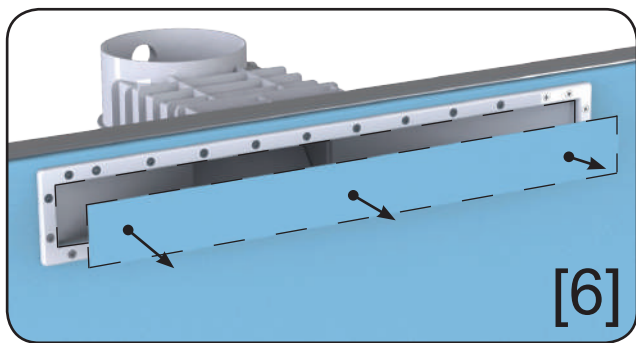

Using a cutter, cut the liner inside of the flange.  
Remove the waste liner material.

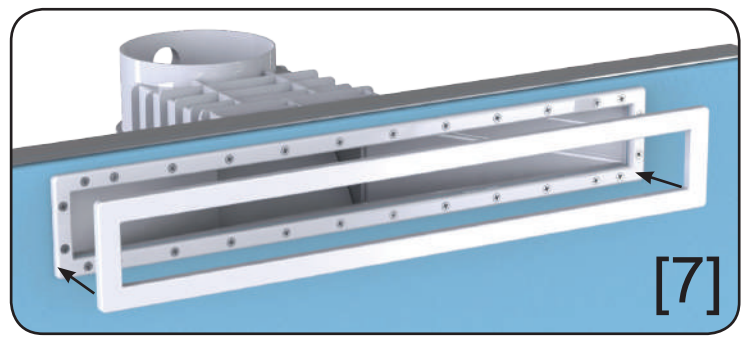

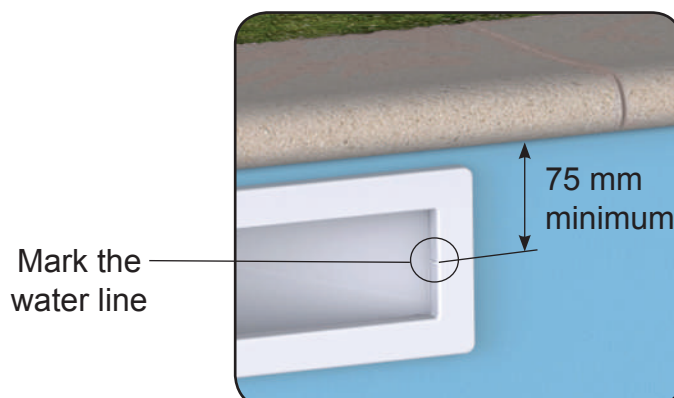

Clip the screw cover on the flange

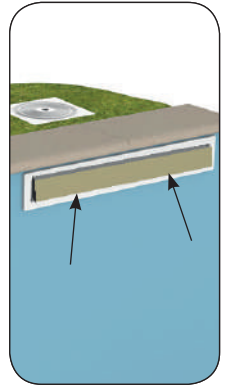
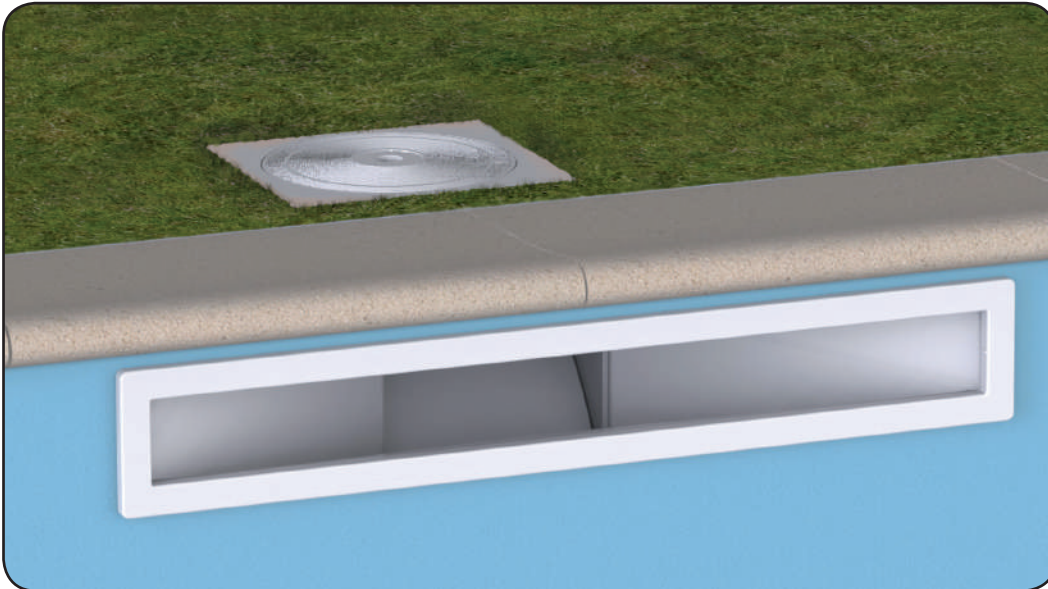

# INSTALLATION ON CONCRETE WALL, CONCRETE LINER OR SHELL

The processes of implementation are the same as with traditional models.



 set up the foam block before pouring concrete.

## PARTS

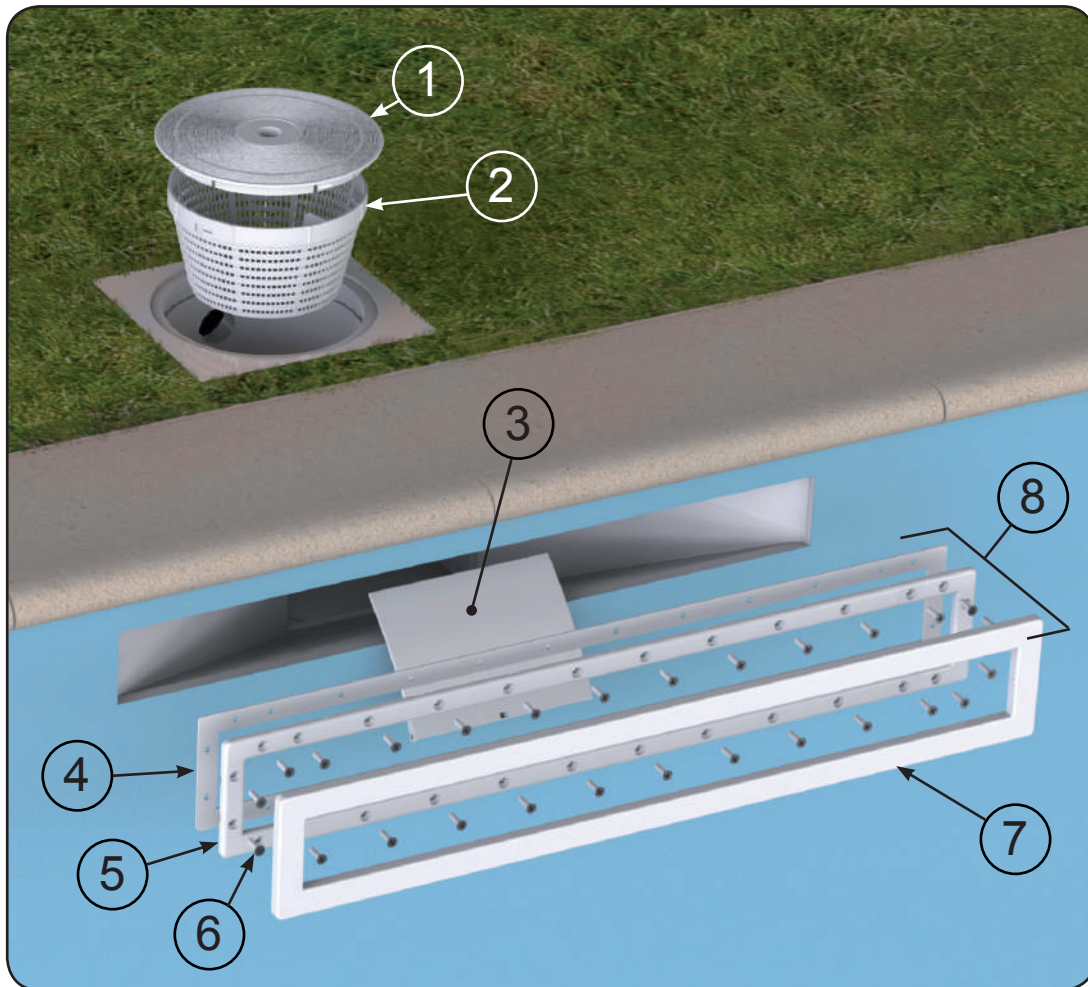

N°	LINER	CONCRETE	SHELL
1	COVER	COVER	COVER
2	BASKET	BASKET	BASKET
3	FLAP	FLAP	FLAP
4	A800 FLAT SEAL	-	A800 FLAT SEAL
5	A800 FLANGE	-	A800 FLANGE
6	A800 SACHET OF LINER SCREWS	-	A800 SACHET OF LINER SCREWS
7	A800 SCREW COVER	-	A800 SCREW COVER
8	A800 LINER KIT	-	A800 LINER KIT



# INSTRUCCIONES DE INSTALACIÓN

## SKIMMER A800

Le damos las gracias por haber elegido un equipo WELTICO y le invitamos a leer detenidamente estas instrucciones para poder disfrutar plenamente del equipo.

- La instalación de este Skimfilter requiere la intervención de personal cualificado.



**IMPORTANTE:** estas instrucciones contienen información sobre las principales medidas de seguridad que se deben adoptar durante la instalación y la puesta en servicio. Por tanto, es indispensable que el instalador y el usuario lean cuidadosamente estas instrucciones antes de comenzar el montaje.

Estas instrucciones también están disponibles en formato PDF y EPUB en el sitio [www.weltico.com](http://www.weltico.com), sección SKIMMER.

### AL RECIBIR EL MATERIAL

Debe haber recibido dos paquetes:

- Un paquete que contiene la boca y sus accesorios.
- Un paquete que contiene el SKIMMER y sus accesorios.

### ESPECIFICACIONES TÉCNICAS:

#### VERSIÓN: PANEL / LINER / HORMIGÓN / ARMazón

- Hecho de ABS
- Desbordamiento Ø 50mm en el exterior
- Salidas: -Ø50mm interior (x2)
- 1"1/2 interior o 2" exterior

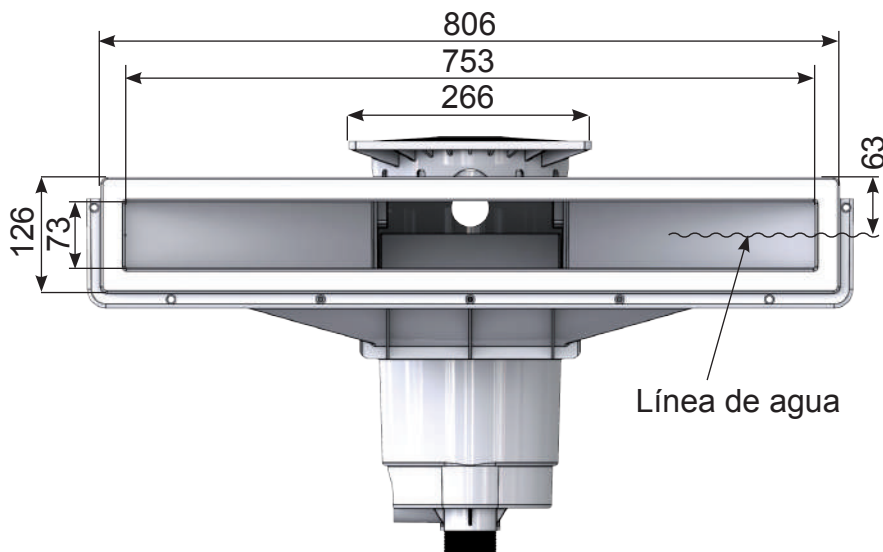
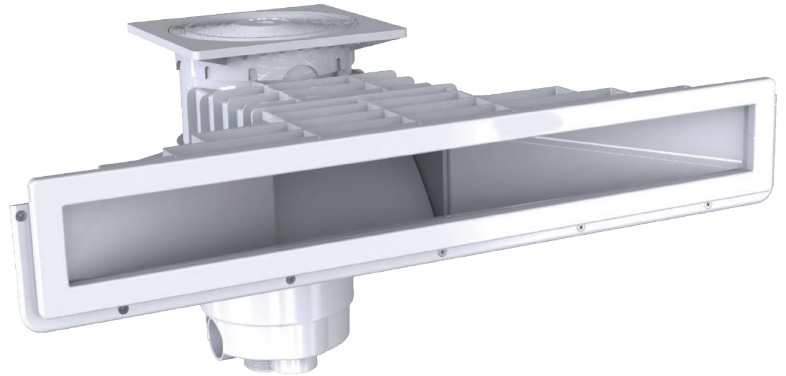

Línea de agua

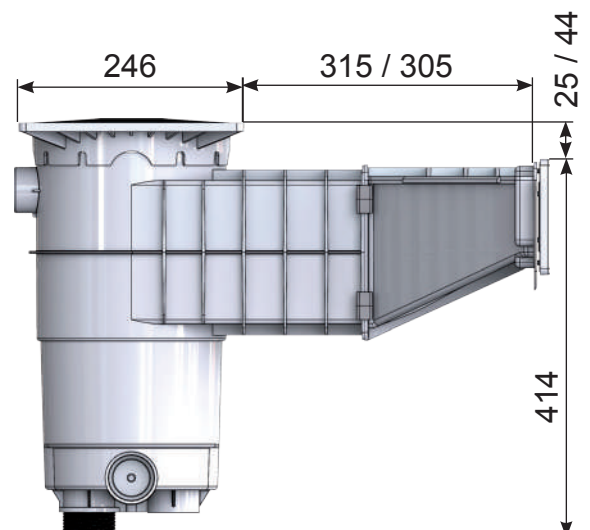



## MONTAJE

Las dos piezas se pueden montar antes o después de la colocación en la pared.

**⚠ ATENCIÓN :** Una vez pegadas las dos piezas con el adhesivo suministrado, es prácticamente imposible separarlas al cabo de media hora.

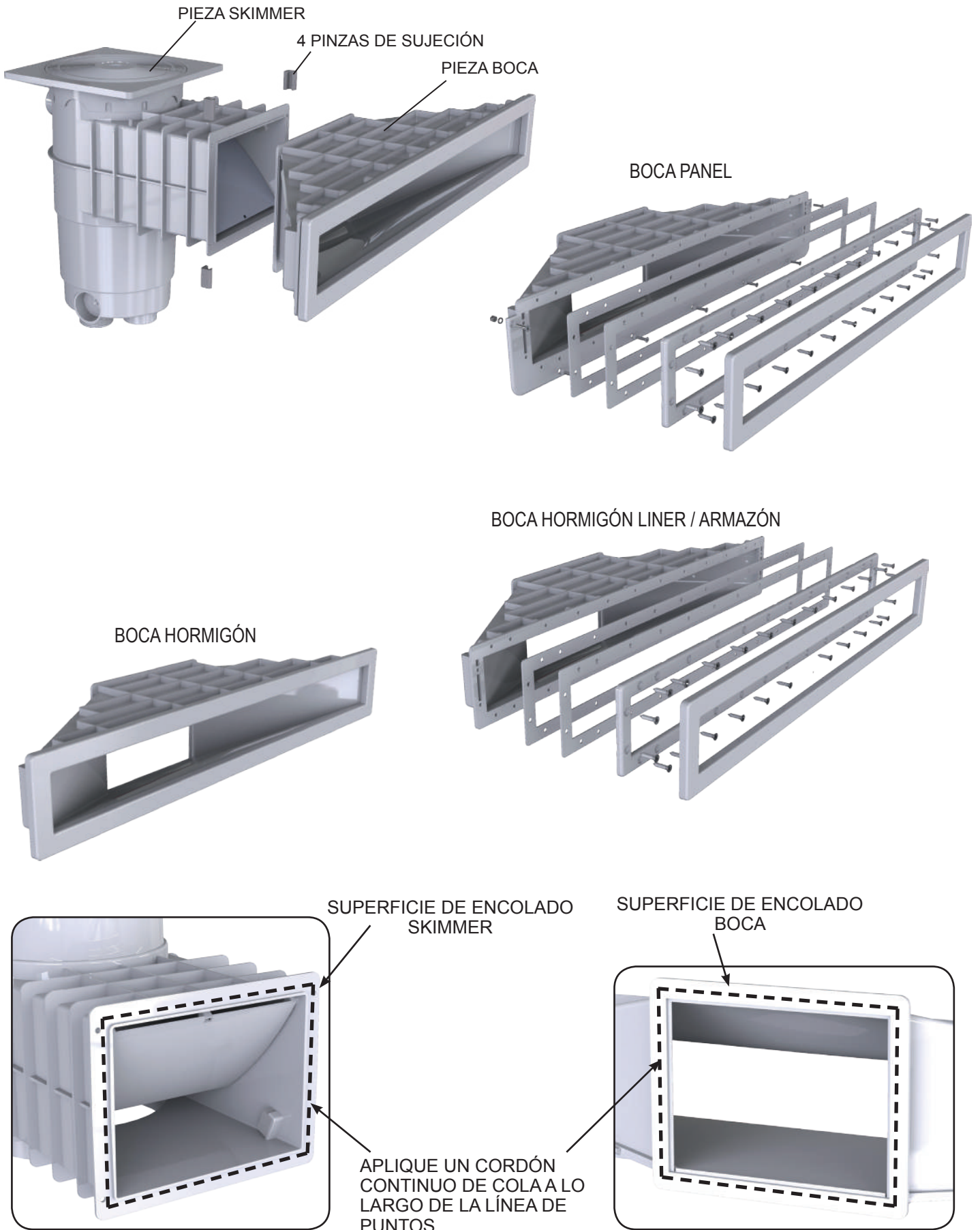

Deslice las 4 pinzas para sujetar las 2 piezas entre sí.

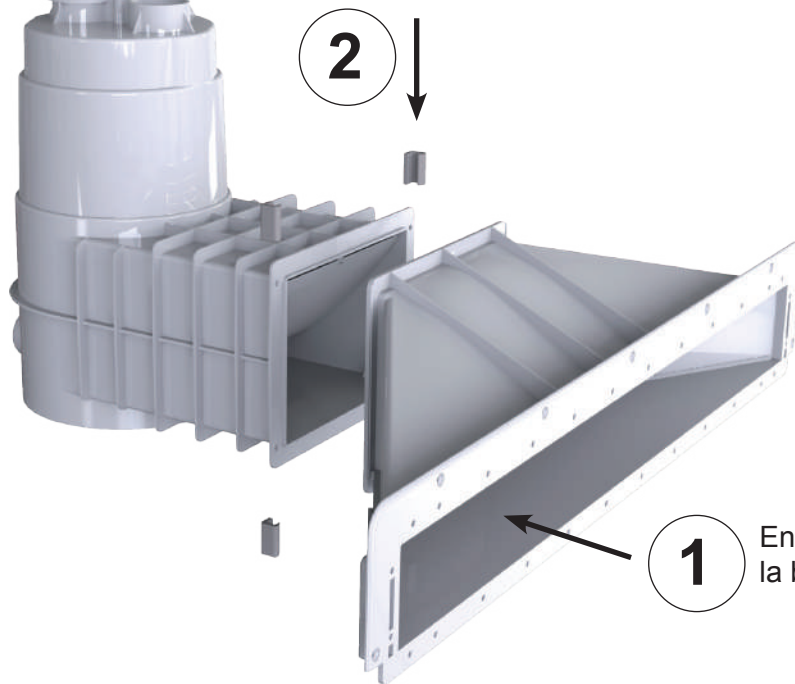

Encaje y pegue el Skimmer a la boca

### COLOCACIÓN EN LA PARED DEL PANEL

Para la versión de panel, se requiere un corte especial para su fijación.



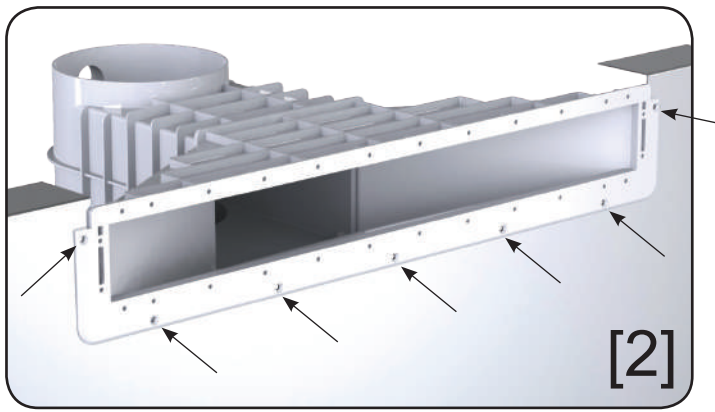

Coloque el conjunto o la boca en posición sobre la pared como se indica anteriormente. Contrataladre en los lugares señalados con flechas para el paso de los tornillos. Atornille con los tornillos suministrados.

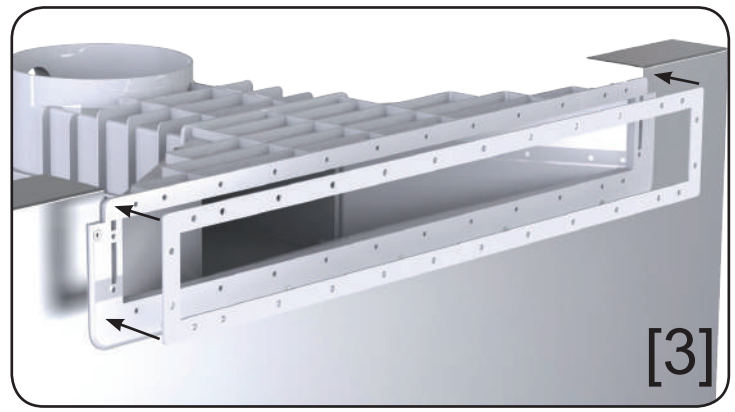

Coloque una junta plana por el lado adhesivo sobre la boca.

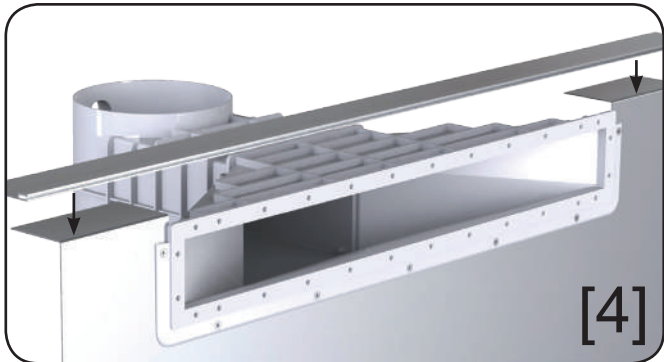

Fije el gancho del liner en la parte superior de la pared. Reforzar una barra de metal que se fije en los jefes previstas.

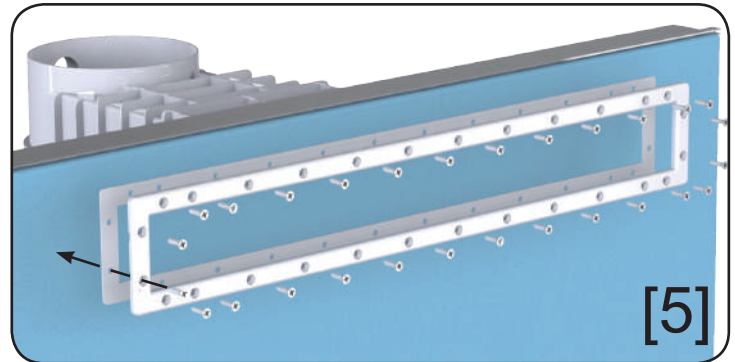

Una vez colocado el liner, ponga la segunda junta plana por el lado adhesivo sobre la brida. Coloque la brida sobre el liner para que coincida con los orificios y luego atornille todos los tornillos.

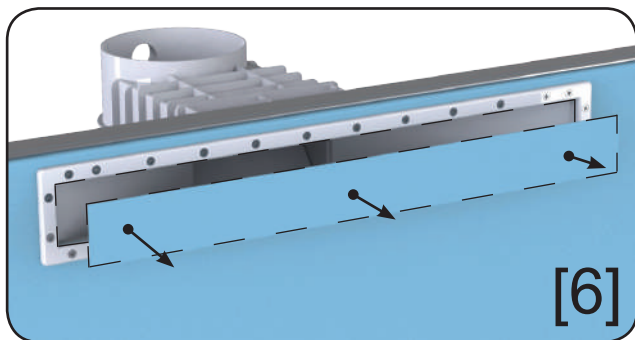

Con ayuda de un cutter, corte el liner por el interior de la brida. Retire el fragmento sobrante de liner.

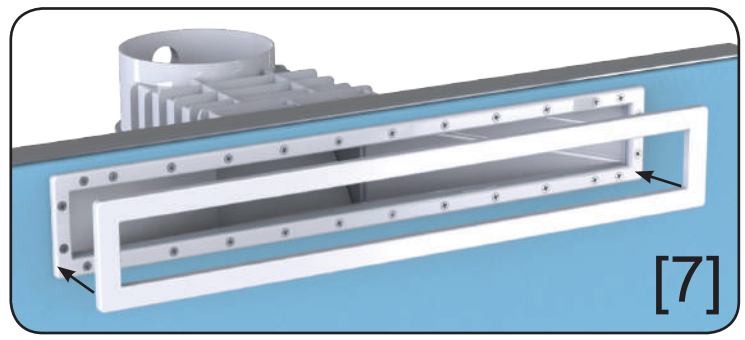

Encaje el tapón de tornillo sobre la brida

Localice la línea de agua

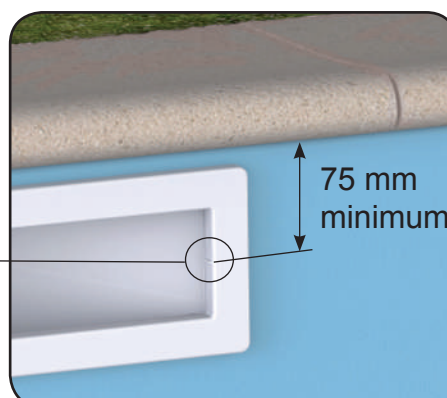



## INSTALACIÓN EN LA PARED DE HORMIGÓN, HORMIGÓN LINER O ARMazón

El procedimiento de instalación es similar al de los modelos tradicionales.

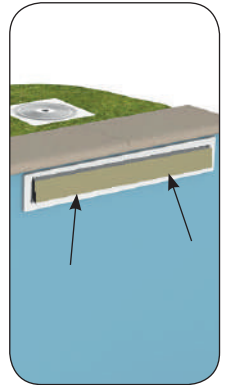
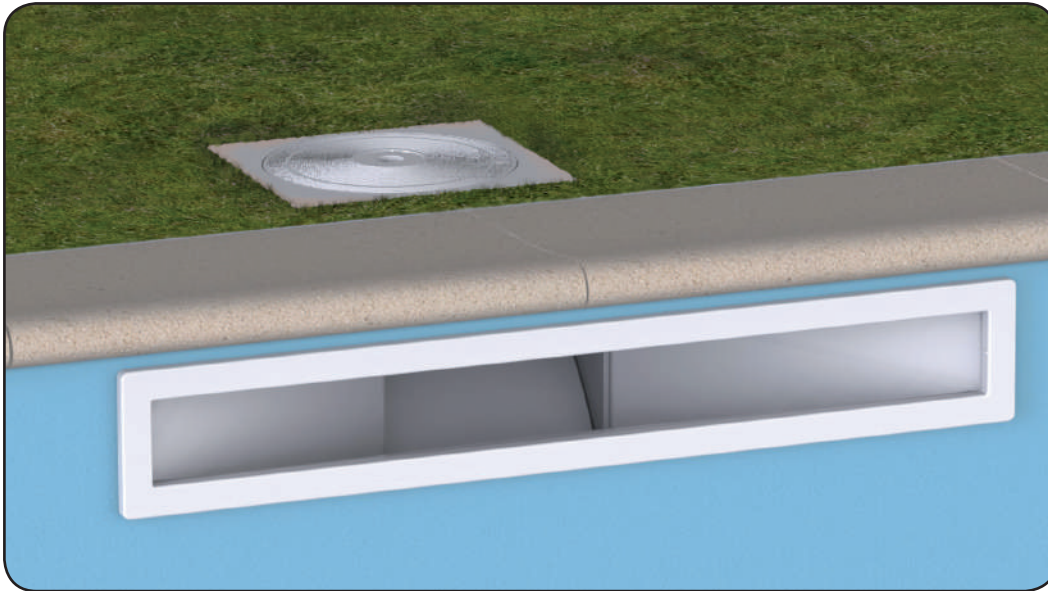

⚠ Configurar el bloque de espuma antes de verter el concreto

### PIEZAS DE RECAMBIO

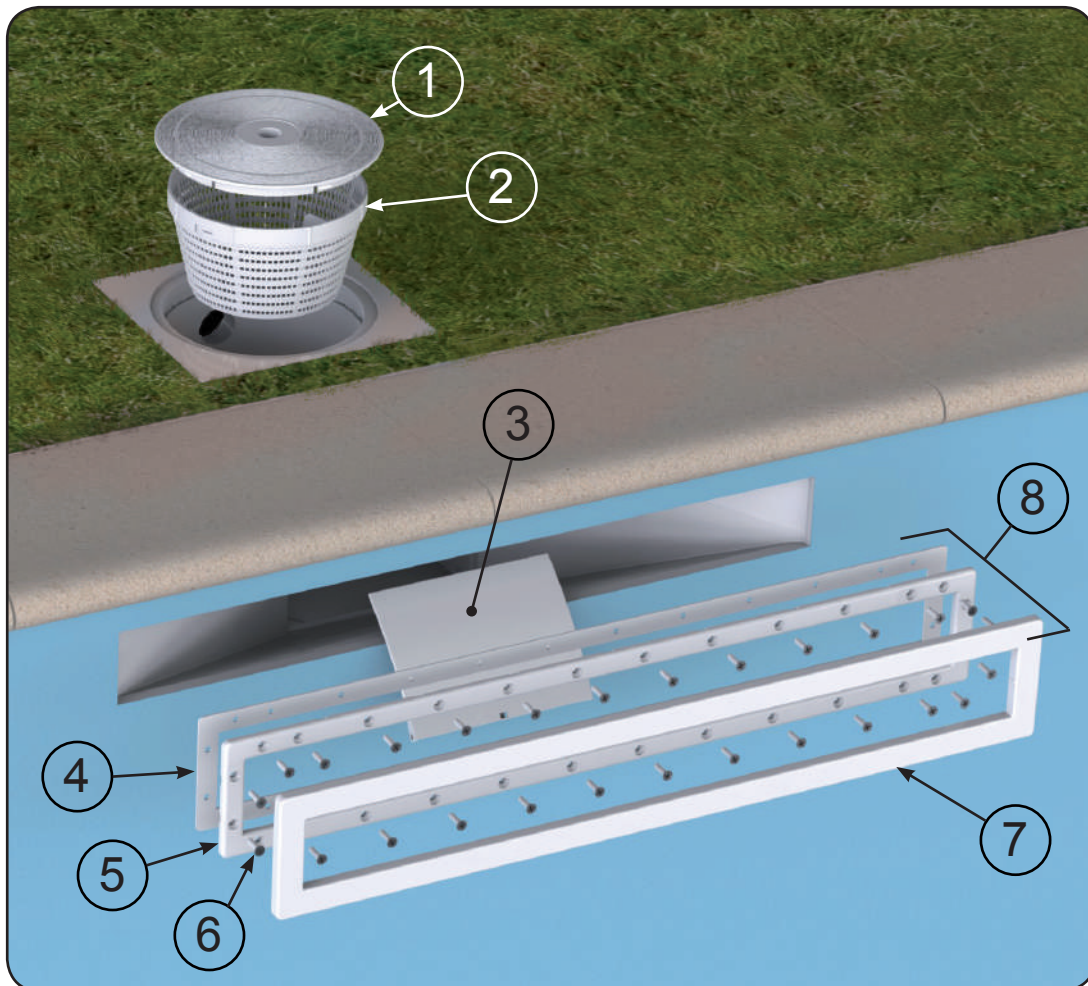

Nº	LINER	HORMIGÓN	ARMazón
1	TAPA	TAPA	TAPA
2	CESTA	CESTA	CESTA
3	COMPUERTA	COMPUERTA	COMPUERTA
4	JUNTA PLANA A800	-	JUNTA PLANA A800
5	BRIDA A800	-	BRIDA A800
6	BOLSA TORNILLO LINER A800	-	BOLSA TORNILLO LINER A800
7	TAPÓN DE TORNILLO A800	-	TAPÓN DE TORNILLO A800
8	KIT LINER A800	-	KIT LINER A800



# ISTRUZIONI PER L'INSTALLAZIONE SKIMMER A800

La ringraziamo per aver scelto un prodotto WELTICO e la invitiamo a leggere con attenzione le istruzioni che le consentiranno di ottenere le migliori prestazioni.

- L'installazione di questo skimmer richiede l'intervento di personale qualificato.



**IMPORTANTE** : questo manuale contiene informazioni importanti sulle misure di sicurezza da adottare al momento dell'installazione e messa in servizio. E' quindi indispensabile che l'installatore e l'utente leggano attentamente queste istruzioni prima di iniziare l'installazione.

Questo manuale è disponibile anche in formato PDF e EPUB sul sito [www.weltico.com](http://www.weltico.com) alla sezione SKIMMER.

## CONSEGNA DEL PRODOTTO

Dovrebbe aver ricevuto una spedizione di 2 colli:

- Un collo contenente la bocchetta e i suoi accessori.
- Un collo contenente il componente SKIMMER e i suoi accessori.

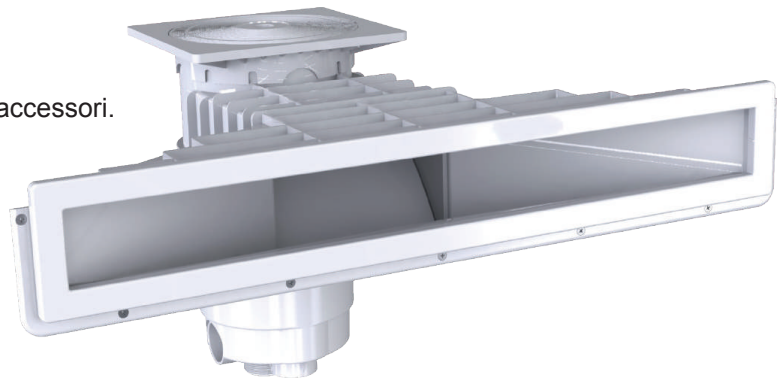

## SPECIFICHE TECNICHE:

VERSIONE: PANNELLO / RIVESTIMENTO / CEMENTO / CUSTODIA

È un prodotto di design e di qualità.  
È un prodotto di design e di qualità.  
È un prodotto di design e di qualità.  
È un prodotto di design e di qualità.

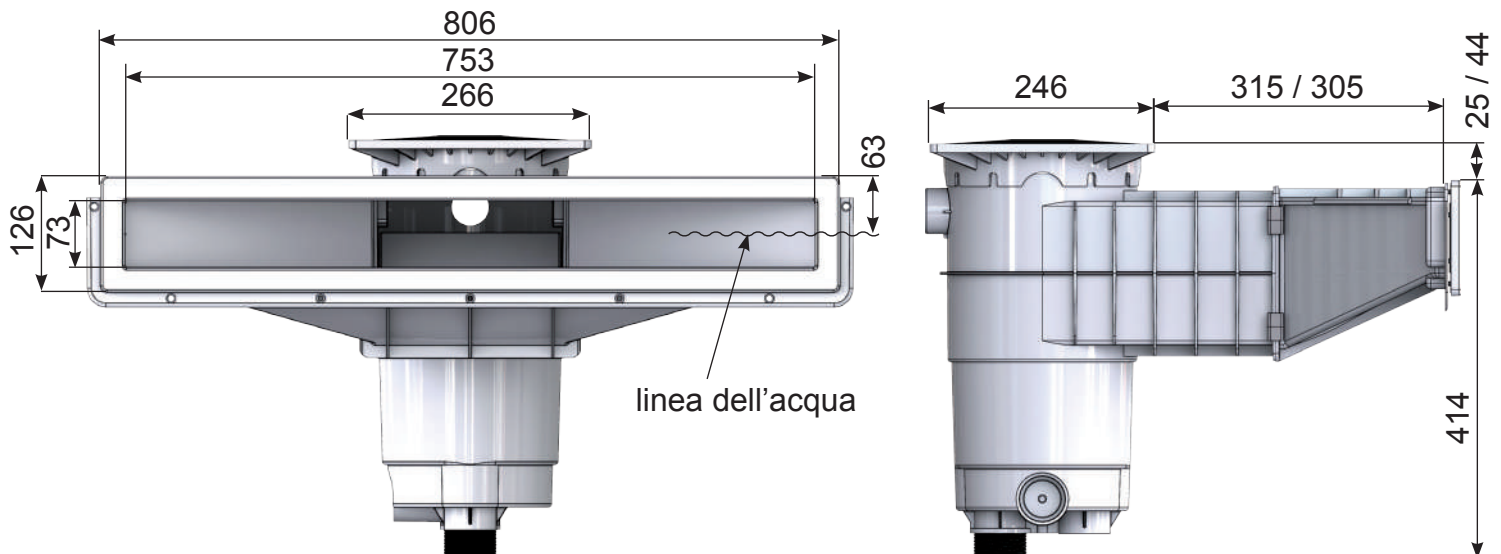

## MONTAGGIO

Le due parti possono essere montate prima o dopo il fissaggio sulla parete.

**ATTENZIONE:** Una volta che le due parti sono state incollate con la colla fornita, è praticamente impossibile separarle dopo circa mezz'ora.

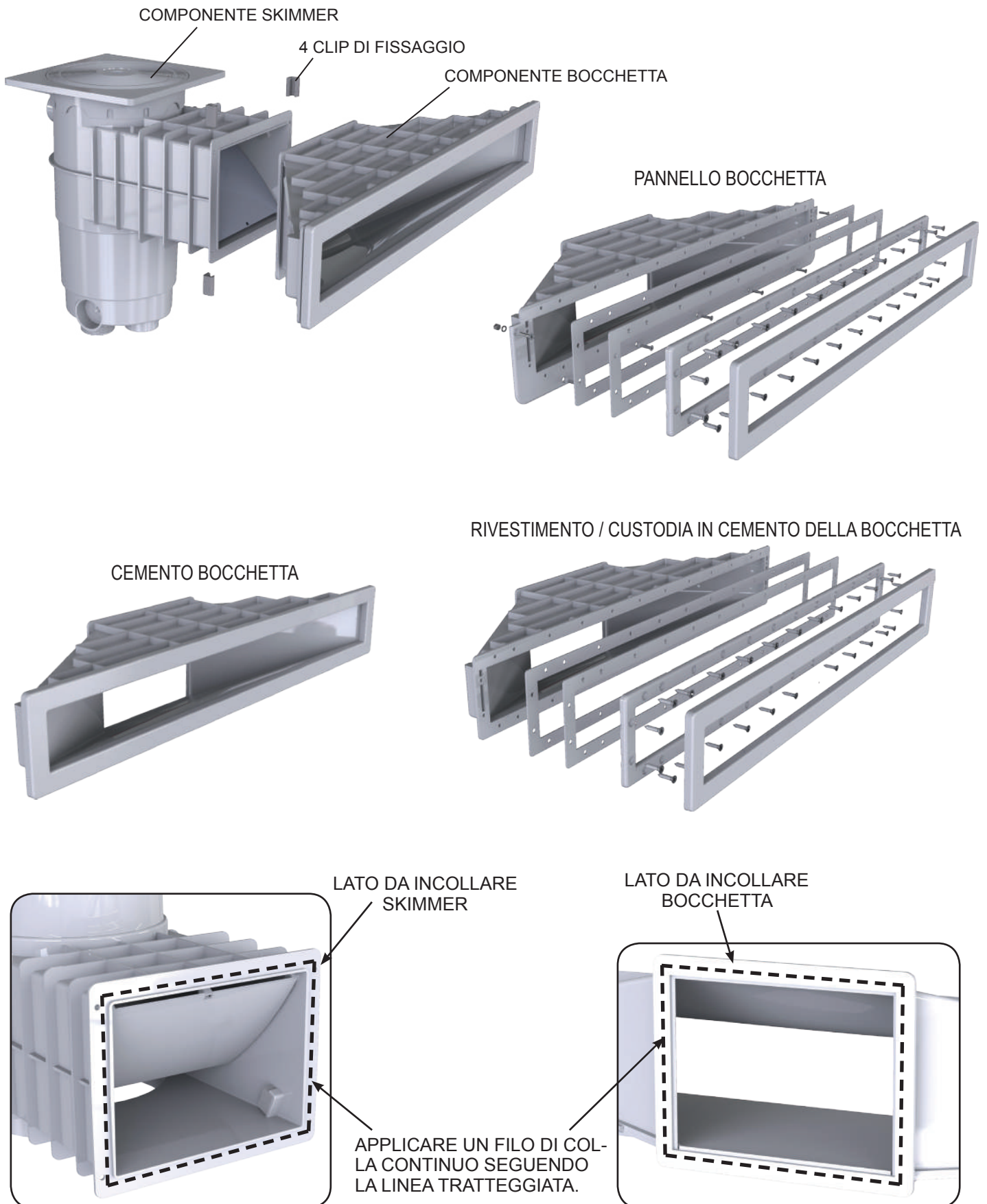

Far scorrere le 4 clip per tenere unite le due parti.

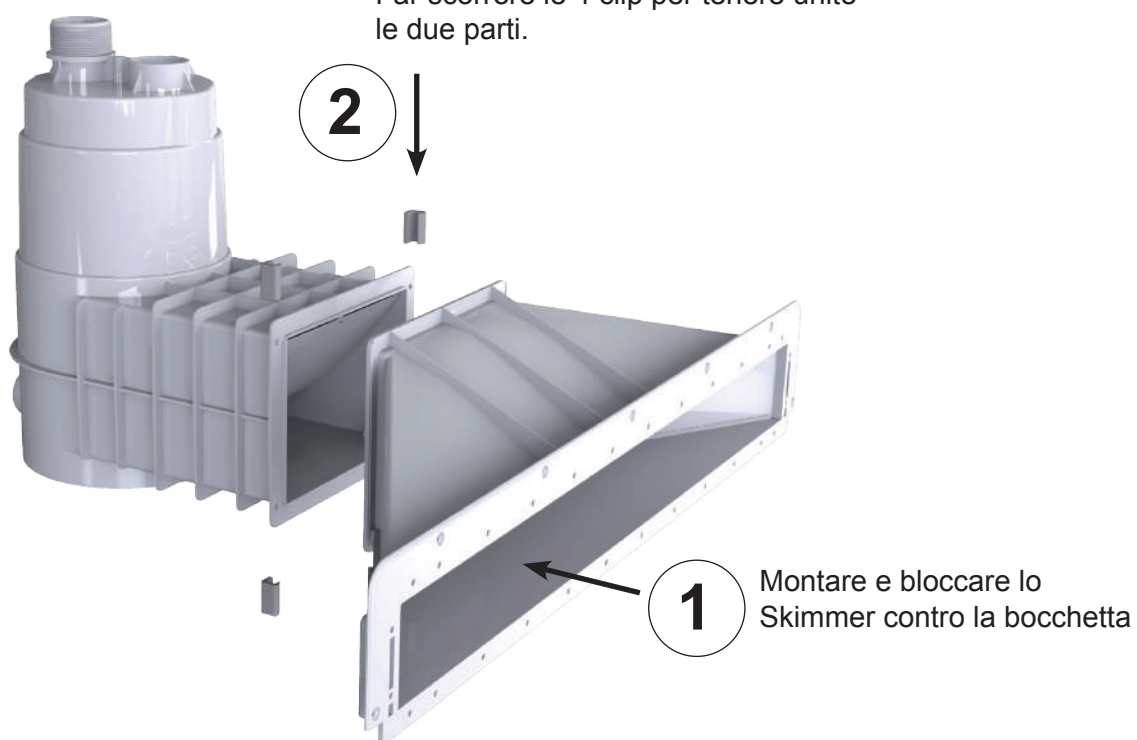

### INSTALLAZIONE SUL PANNELLO A PARETE

La versione a pannello richiede un taglio particolare per il fissaggio.



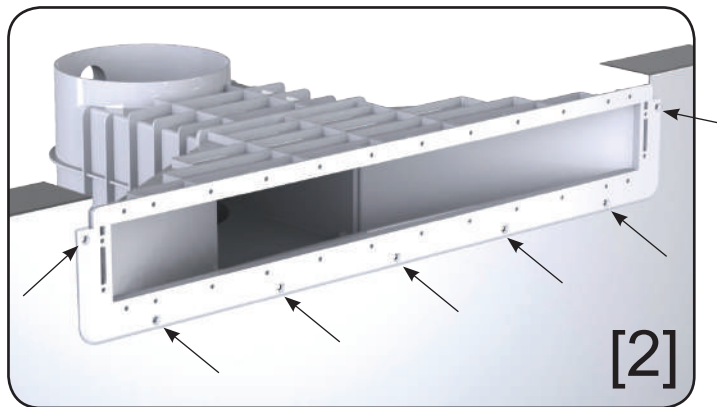

Mettete tutto l'insieme o la bocchetta in posizione sulla parete come sopra. Applicare dei fori con il trapano per il passaggio delle viti. Fissare con le viti in dotazione.

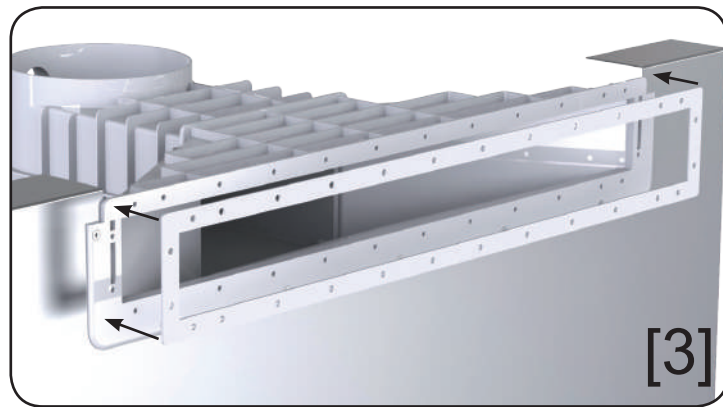

Inserire una guarnizione piatta sul lato adesivo della bocchetta..

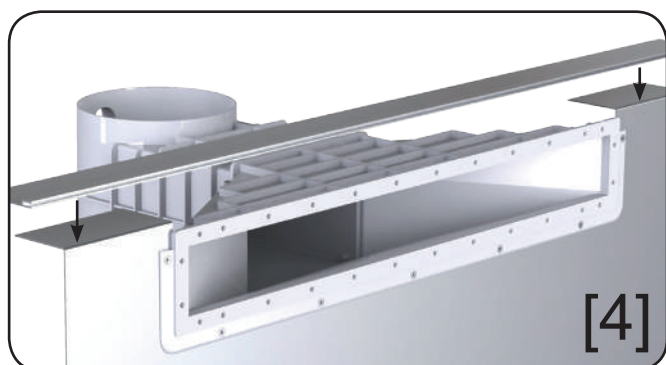

Fissare il blocco rivestimento sulla parte superiore della parete. Rafforzare una boccola metallica da fissare su capi forniti.

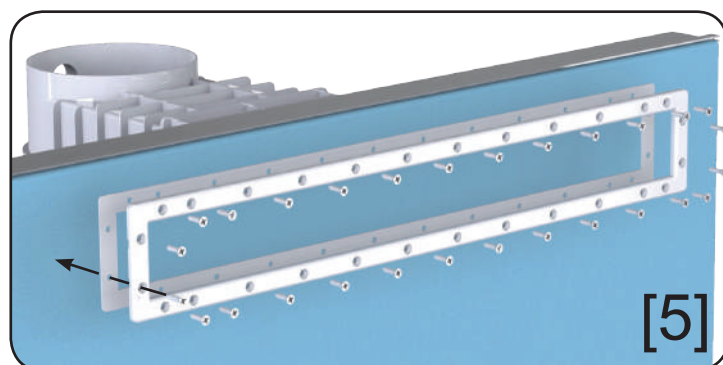

Una volta posizionato il rivestimento, inserire la seconda guarnizione piatta sul lato adesivo della flangia. Posizionare la flangia sul rivestimento in modo da far corrispondere i fori e le viti e serrare tutte le viti.

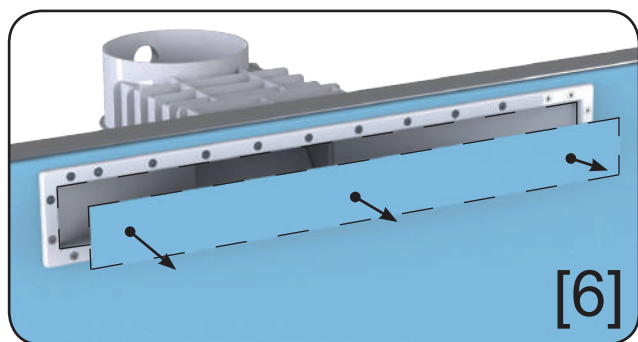

Con un coltello, tagliare il rivestimento interno della flangia. Togliere il rivestimento in eccesso.

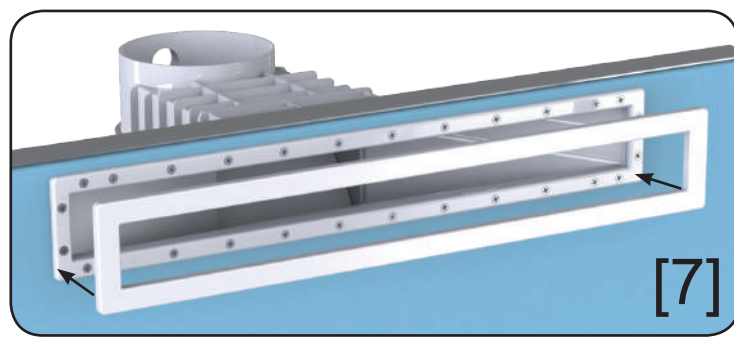

Inserire il coperchio a vite sulla flangia

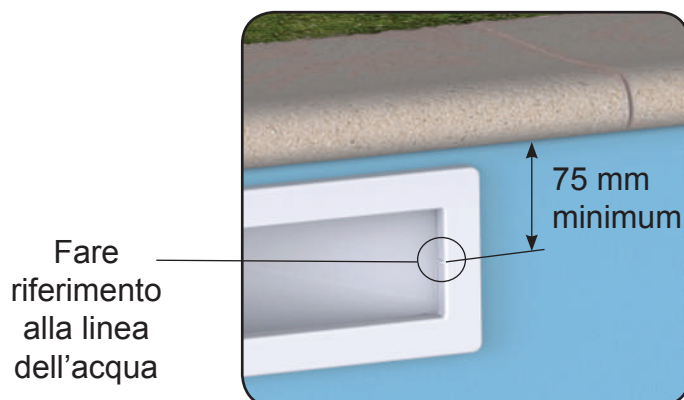



# INSTALLAZIONE SU MURO DI CEMENTO, RIVESTIMENTO IN CEMENTO O CUSTODIA

Il procedimento di installazione è simile a quello dei modelli convenzionali.

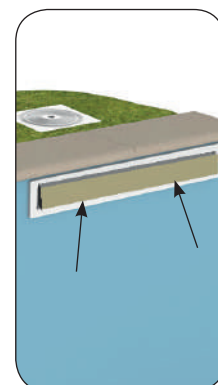
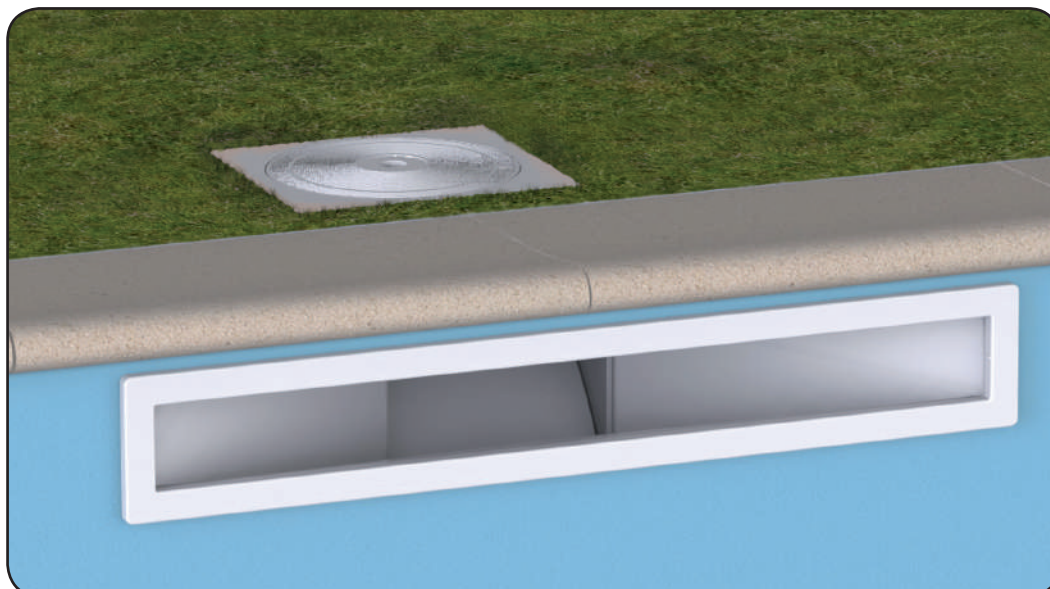

**!** NB : imposta il blocco di schiuma prima di versare il cement

## PARTI DI RICAMBIO

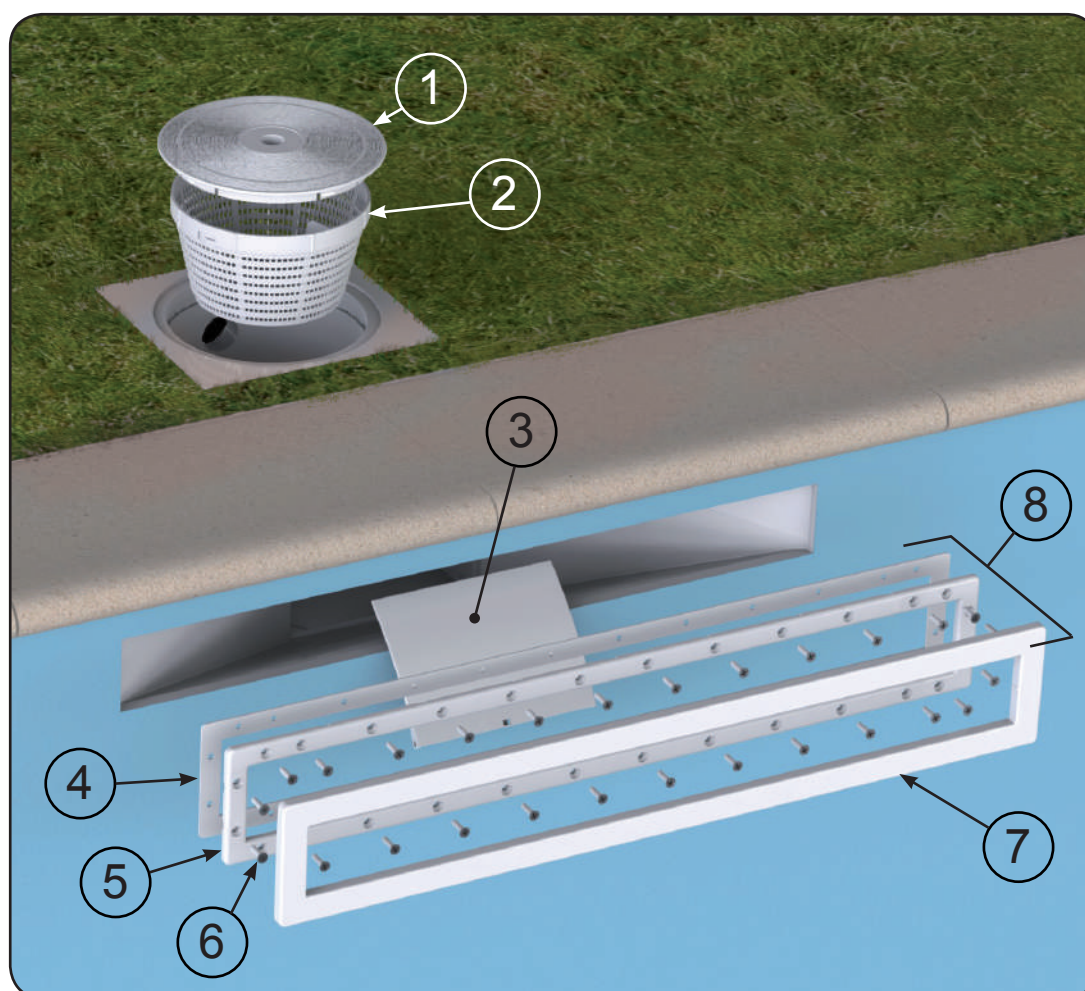

N°	RIVESTIMENTO	CEMENTO	CUSTODIA
1	COPERTINA	COPERTINA	COPERTINA
2	CESTELLO	PANIER	PANIER
3	STECCATO	STECCATO	STECCATO
4	GUARNIZIONE PIATTA A800	-	GUARNIZIONE PIATTA A800
5	FLANGIA A800	-	FLANGIA A800
6	SACCA RIVESTIMENTO VITE A800	-	SACCA RIVESTIMENTO VITE A800
7	COPERCHIO A VITE A800	-	COPERCHIO A VITE A800
8	KIT LINER A800	-	KIT LINER A800

# INSTALLATIONSANWEISUNG SKIMFILTER A800

Wir danken Ihnen dafür, dass Sie sich für das Material WELTICO entschieden haben und wir bitten Sie darum, diese Anweisung sorgfältig durchzulesen, um ein sehr zufriedenstellendes Ergebnis zu erzielen.

- Für die Installation dieses Skimmers ist qualifiziertes Fachpersonal notwendig.



**WICHTIG:** Diese Anweisung enthält wichtige Informationen über die Sicherheitsmaßnahmen, die bereits zum Zeitpunkt der Installation und Inbetriebnahme beachtet und durchgeführt werden müssen. Deshalb ist es unabdingbar, dass der Installateur und der Benutzer diese Anleitungen vor der Montage aufmerksam durchlesen.

Dieses Handbuch ist auch auf [www.weltico.com](http://www.weltico.com) in der Rubrik Skimfilter als PDF- und EPUB-Format verfügbar.

## BEI EMPFANG DES MATERIALS

müssten Sie zwei Pakete erhalten haben:

- Ein Paket enthält einen Abzug und das zugehörige Zubehör.
- Ein Paket enthält den Skimfilter und das dazugehörige Zubehör.

## TECHNISCHE DATEN:

### VERSION: TAFEL / LINER / BETON / SCHALE

- Hergestellt aus ABS
- Überlauf Ø 50mm außen
- Auslassdurchmesser: -Ø50mm innen (x2)  
- 1"1/2 innen oder 2" außen

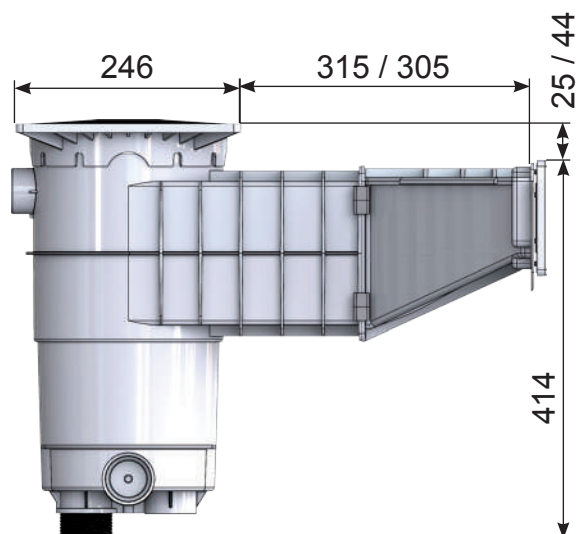
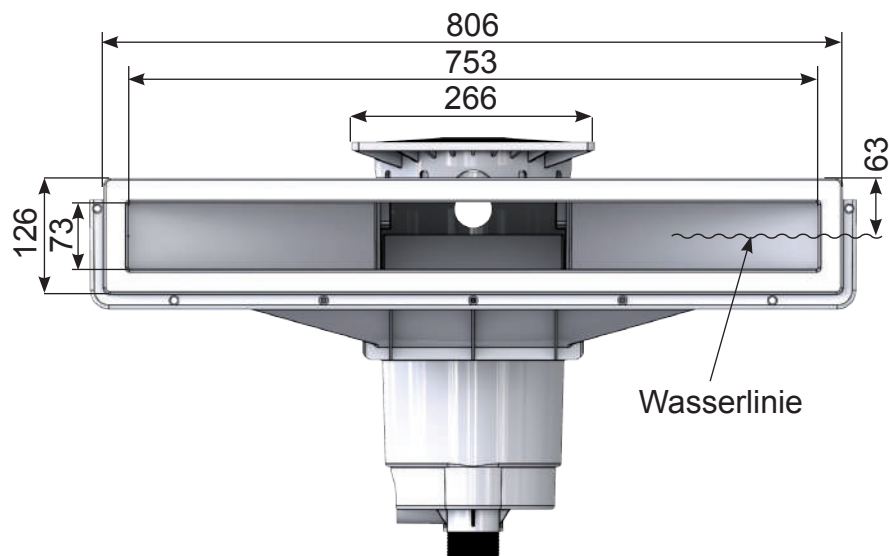
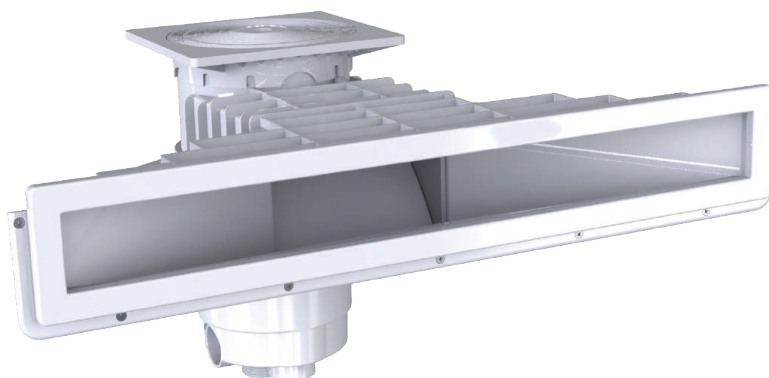

# MONTAGE

Die beiden Teile können vor oder nach der Montage an der Wand zusammengesetzt werden.



**ACHTUNG:** Sobald die beiden Teile länger als eine halbe Stunde mit dem mitgelieferten Leim zusammengeklebt sind, ist es praktisch nicht mehr möglich, sie zu trennen.

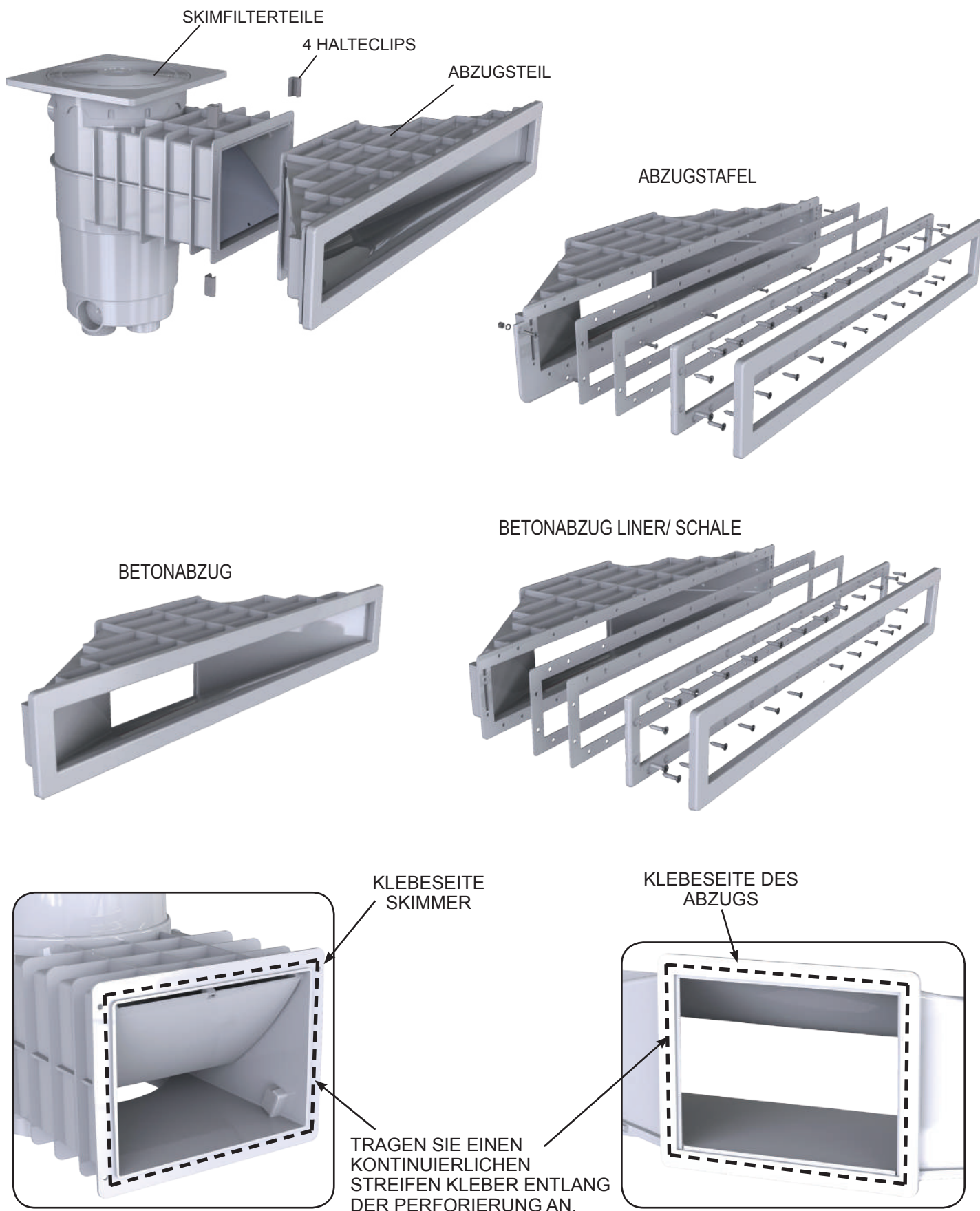

Schieben Sie die 4 Clips auf die zwei Teile, damit sie zusammengehalten werden.

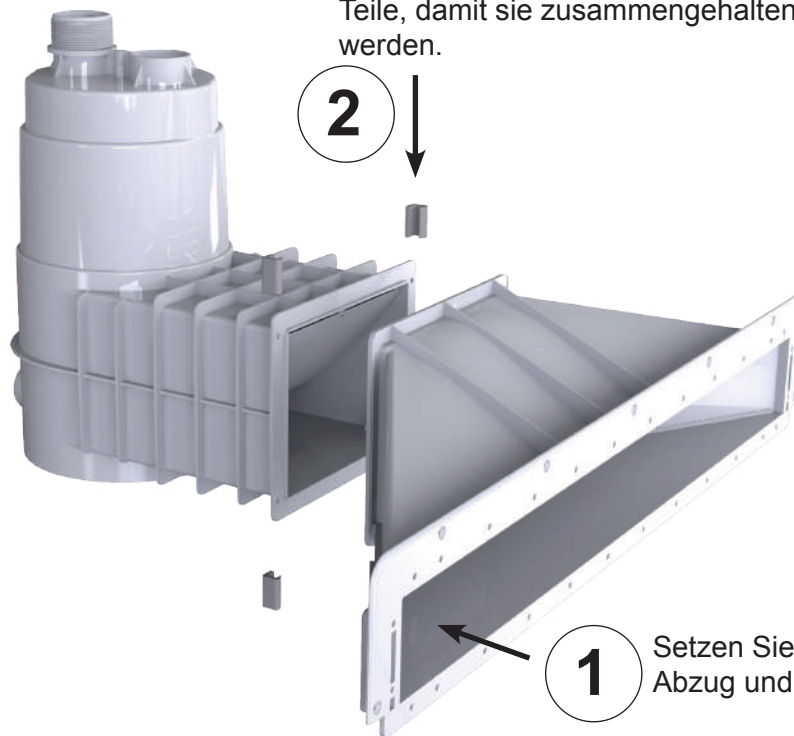

### MONTAGE AN DIE WAND DER ABZUGSTAFEL

Die Wandversion erfordert einen besonderen Zuschnitt für seine Fixierung.





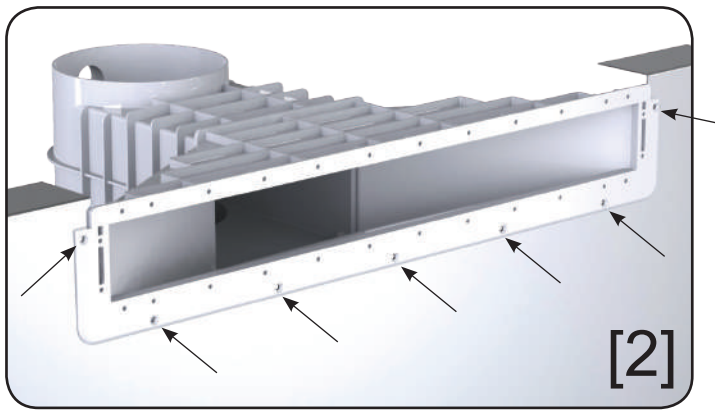

Bringen Sie das Ganze und den Abzug in die unten beschriebene Position.

Durchbohren Sie die mit einem Kreuz versehenen Bereiche, um das Eindrehen der Schrauben zu ermöglichen. Mit den mitgelieferten Schrauben befestigen.

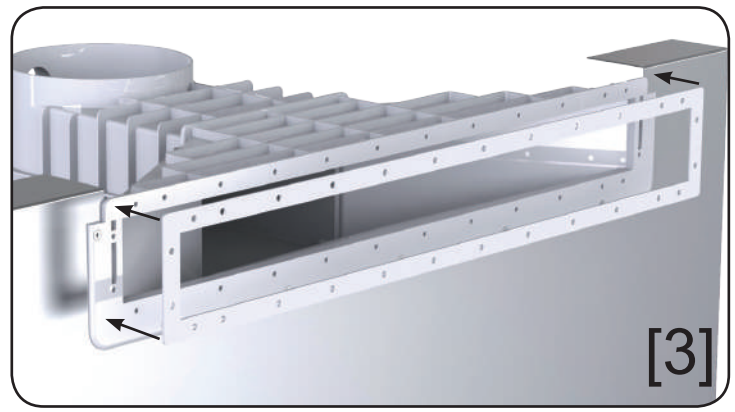

Legen Sie eine Flachdichtung auf die Klebeseite des Auszugs.

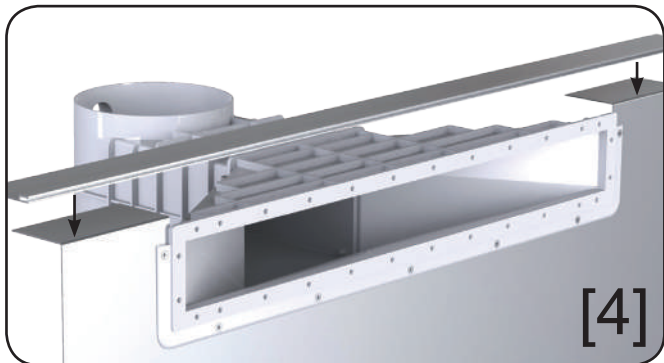

Fixieren Sie den Linerhaken auf die obere Seite der Wand. Verstärken Sie eine Metallhülse auf Bosse festgesetzt werden.

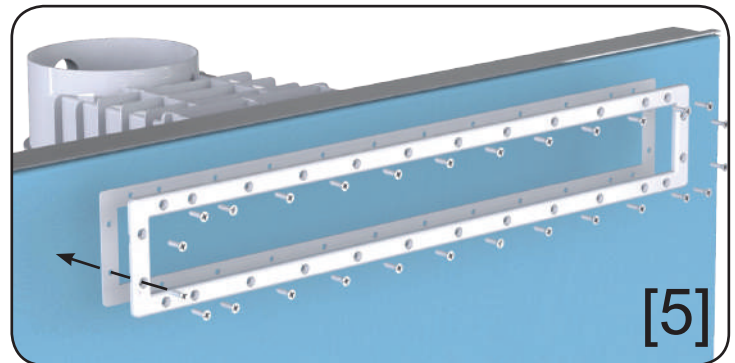

Ist der Linerhaken einmal befestigt, legen Sie die zweite Flachdichtung auf die Klebeseite des Flansches. Positionieren Sie den Flansch auf den Liner, bis die Lächer übereinstimmen. Dann alle Schrauben festziehen.

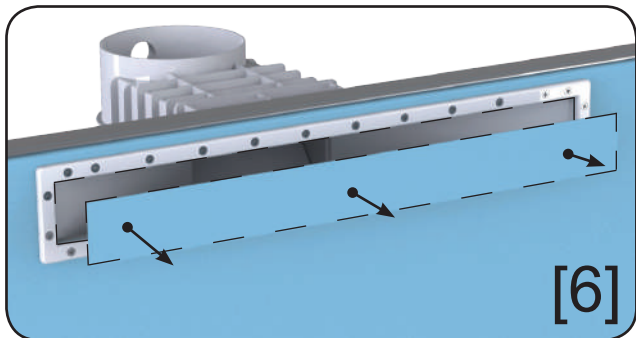

Schneiden Sie den Liner im Innern des Flansches mithilfe eines Cutters. Entfernen Sie den Chute-Liner.

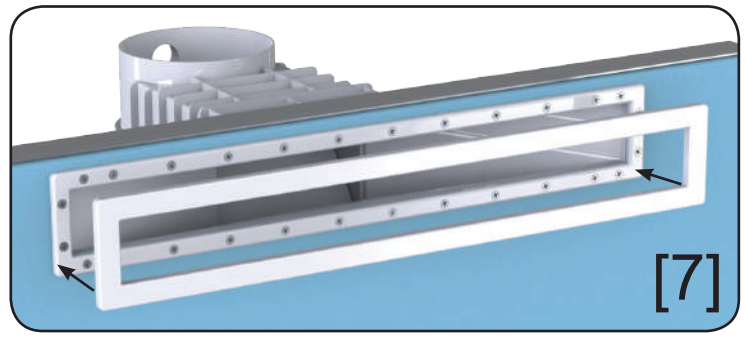

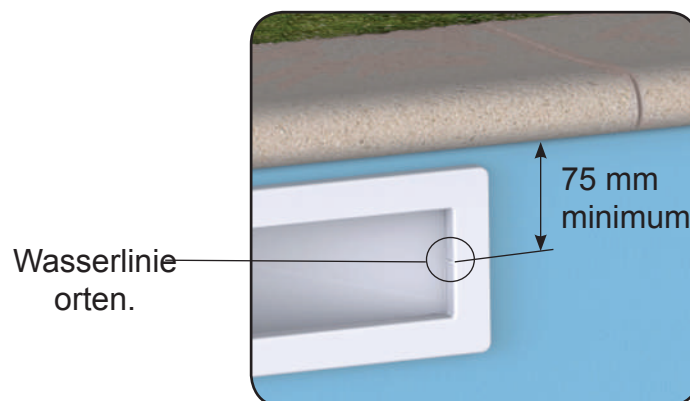

Befestigen Sie den Flickzapfen auf dem Flansch.

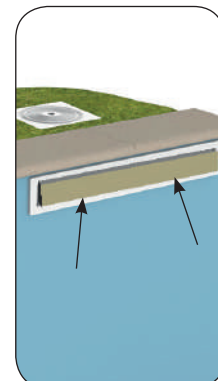
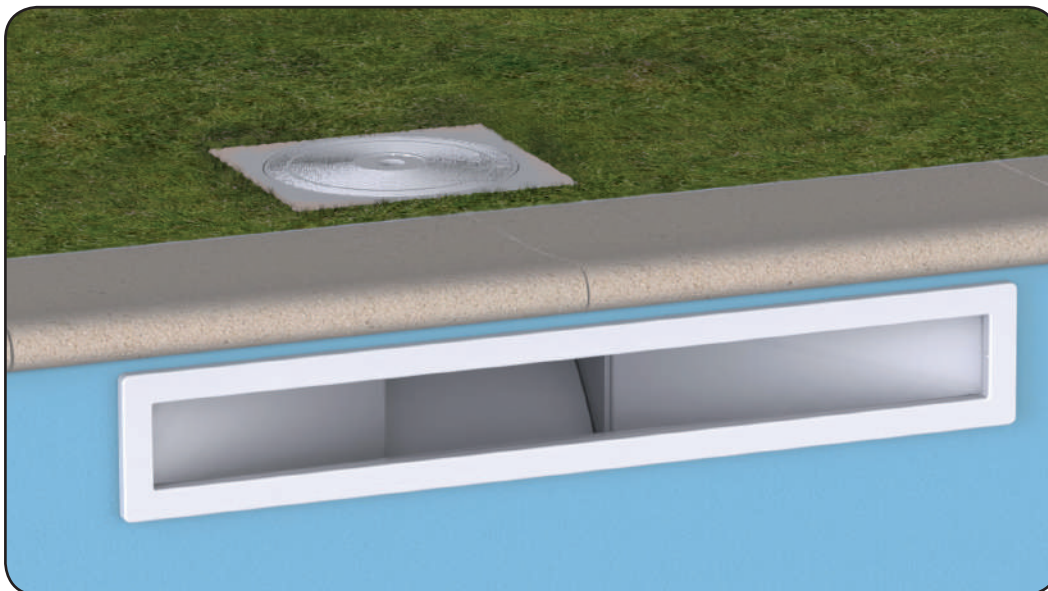

## BEFESTIGUNG AUF DER BETONWAND, BETON-LINER ODER VERKLEIDUNG

Der Befestigungsvorgang erfolgt auf die gleiche Art und Weise wie bei traditionellen Modellen.



 Den Schaumblock vor dem Betonieren aufstellen

### UNBAHÄNGIGE TEILE

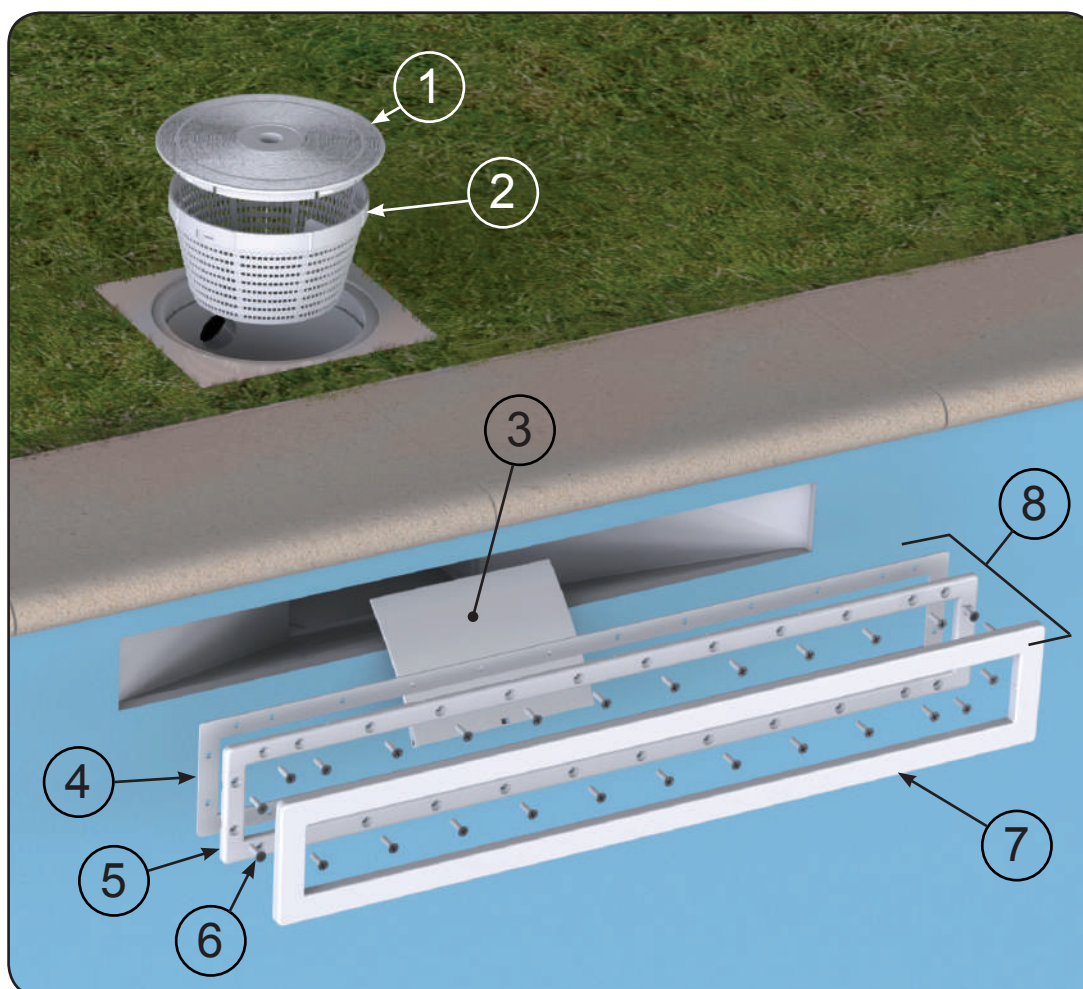

N°	LINER	BETON	SCHALE
1	ABDECKUNG	ABDECKUNG	ABDECKUNG
2	KORB	KORB	KORB
3	KLAPPE	KLAPPE	KLAPPE
4	FLACHDICHTUNG A800	-	FLACHDICHTUNG A800
5	FLANSCH A800	-	FLANSCH A800
6	BEUTEL MIT LINER-SCHRAUBEN A800	-	BEUTEL MIT LINER-SCHRAUBEN A800
7	SCHRAUBENBLENDE A800	-	SCHRAUBENBLENDE A800
8	LINER-KIT A800	-	LINER-KIT A800

## MONTAGE-INSTRUCTIES SKIMMER A800

Hartelijk dank voor het kiezen voor apparatuur van WELTICO en wij nodigen u uit om deze instructies aandachtig te lezen waardoor u er alle voldoening uit kunt halen.

- Het installeren van deze zuiveringsinstallatie dient uitgevoerd te worden door gekwalificeerde personen.



**BELANGRIJK:** deze instructie bevat zeer belangrijke informatie over de veiligheidsmaatregelen die in acht genomen moeten worden tijdens de installatie en de ingebruikname. Het is bijgevolg noodzakelijk dat de installateur en de gebruiker deze instructies aandachtig doorlezen voorafgaand aan de montage.

Deze instructie is eveneens beschikbaar in PDF- en EPUB-formaat op [www.weltico.com](http://www.weltico.com) in de rubriek SKIMMER.

### BIJ ONTVANGST VAN HET MATERIAAL

U moet een geheel van 2 pakketten ontvangen hebben:

- Eén pakket bevat de behuizing en de accessoires.
- Eén pakket bevat het SKIMMER-onderdeel en de accessoires.

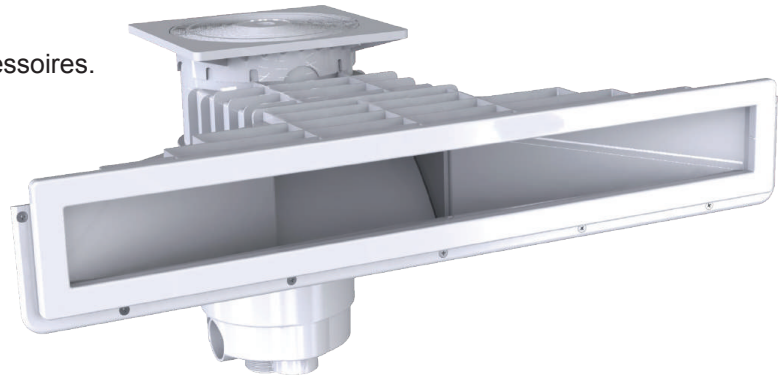

### TECHNISCHE SPECIFICATIES:

#### VERSIE: PANEEL / LINER / BETON / CASCO

- Gemaakt van ABS
- Overloop Ø 50mm buiten
- Uitlaat :
  - Ø50mm binnenin (x2)
  - 1"1/2 binnen of 2" buiten

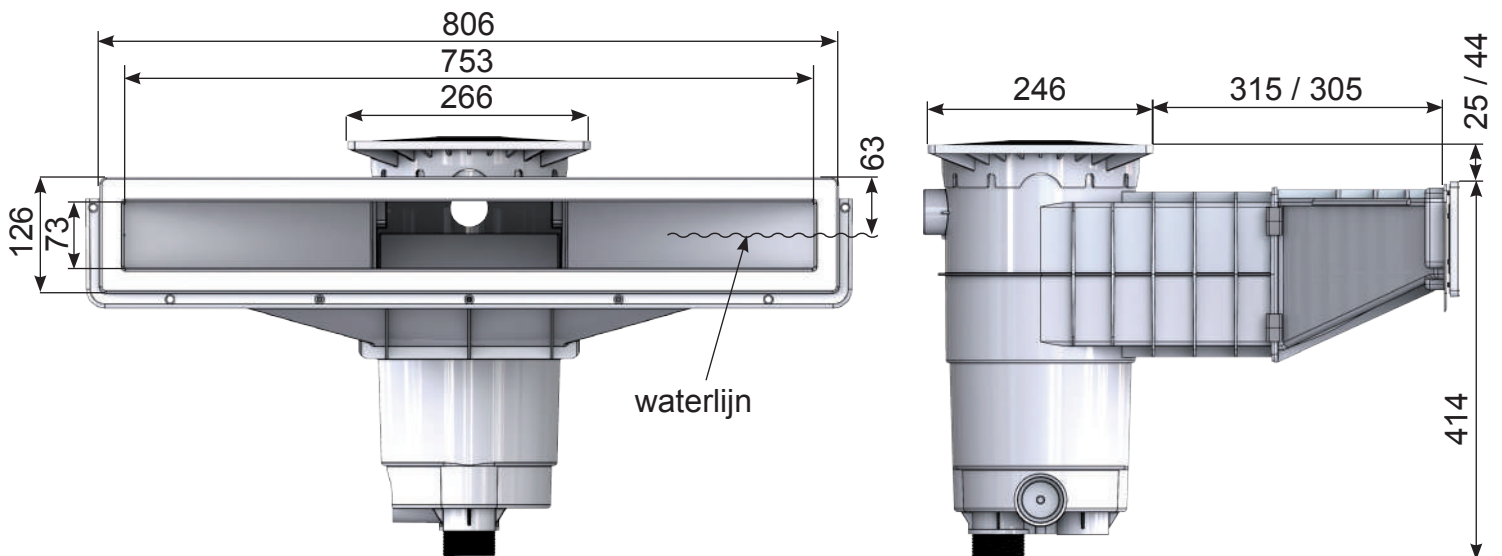



## MONTAGE

De twee delen kunnen voor of na de ingebruikname gemonteerd worden op hun plek op de wand.

**! LET OP:** Wanneer de twee delen gelijmd zijn met de geleverde lijm, dan is het praktisch onmogelijk om ze te scheiden na een 1/2 uur.

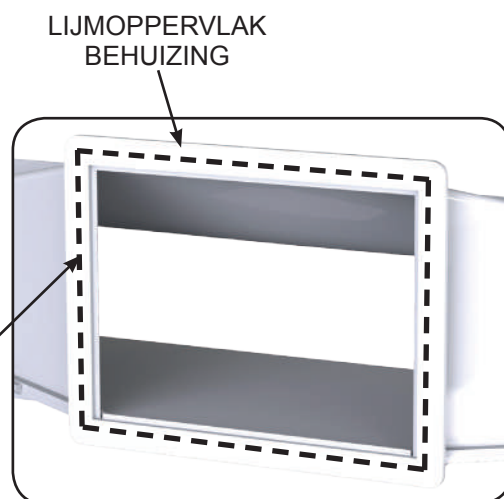
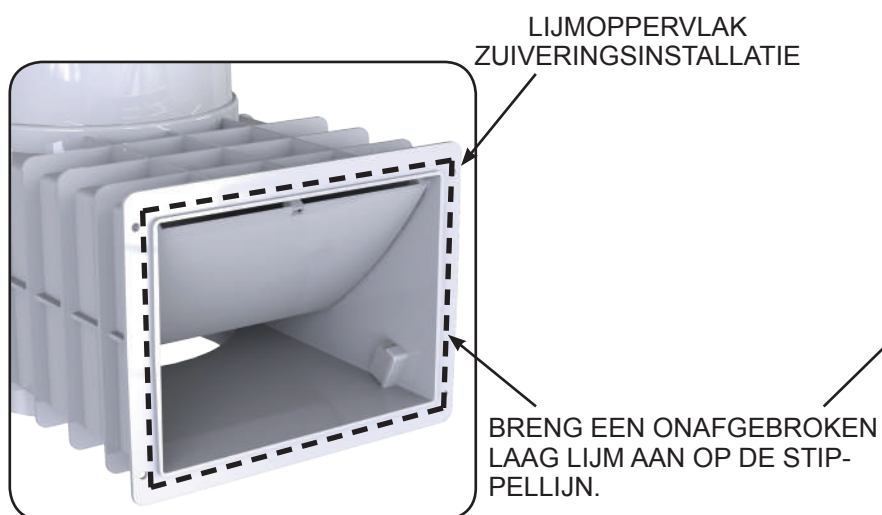
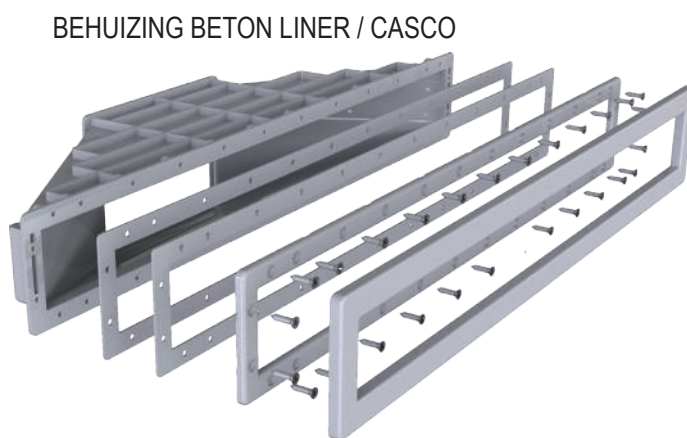
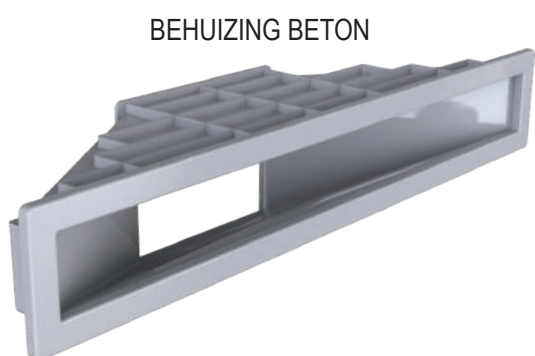
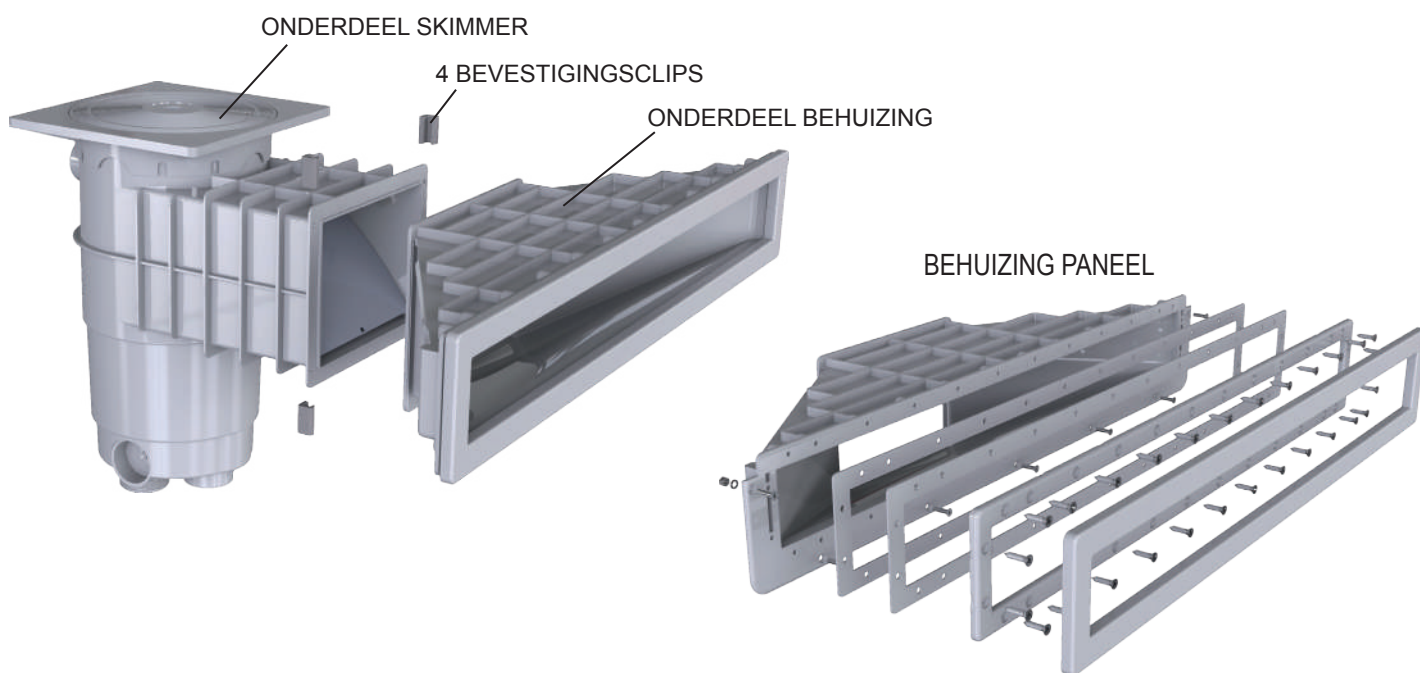



Schuif de 4 bevestigingsclips om de 2 stukken tegen elkaar te houden.

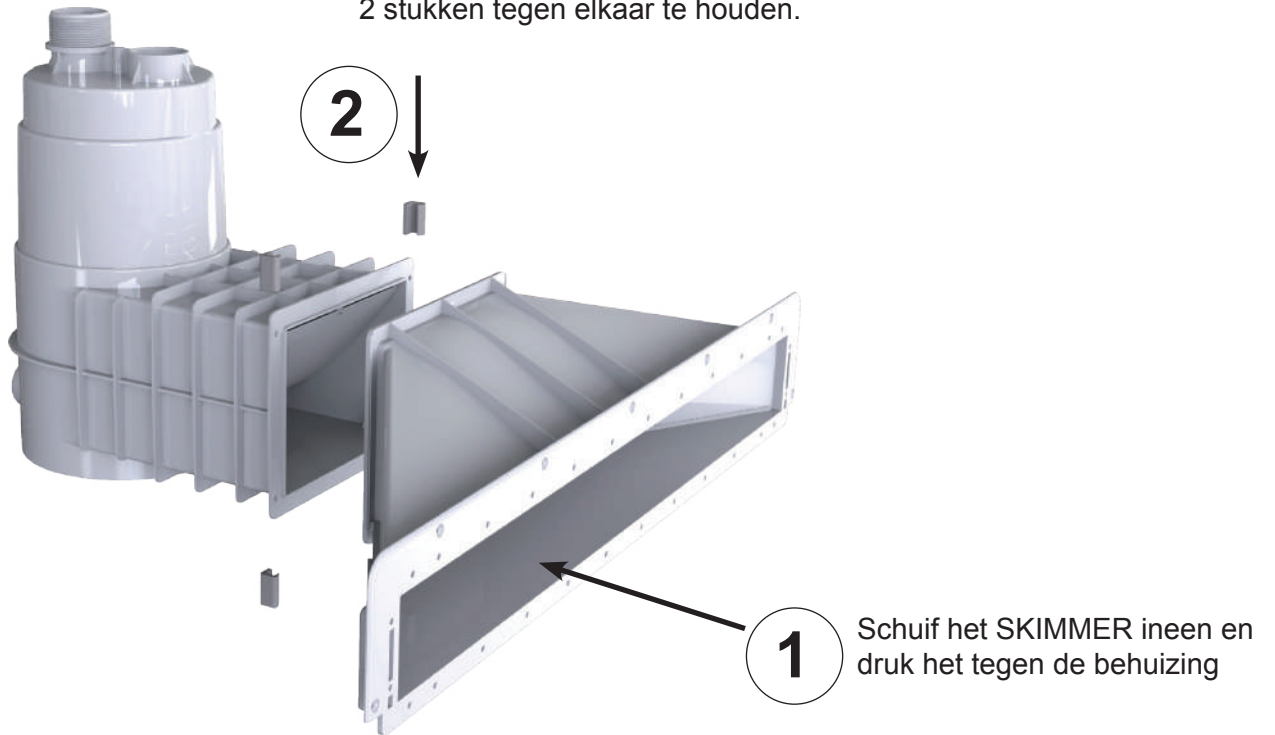

### PLAATSEN OP HET WANDPANEEL

De paneelversie vraagt een specifieke voorsnijding voor de bevestiging.



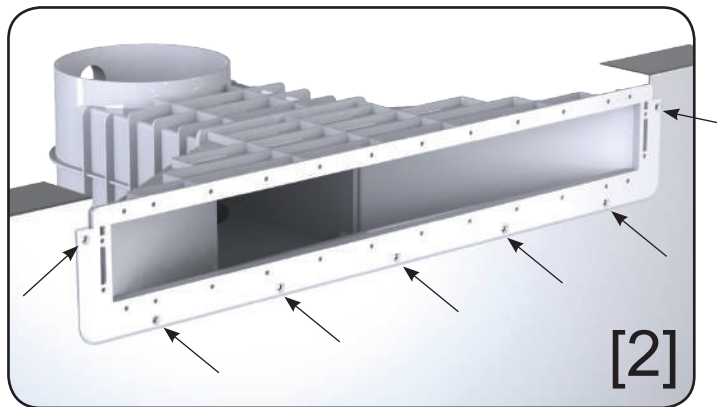

Plaats het geheel of de behuizing op zijn plek op de wand zoals hierboven.  
 Doorboor op aangewezen plaatsen voor de doorgang van schroeven. Klink het vast met de geleverde schroeven.

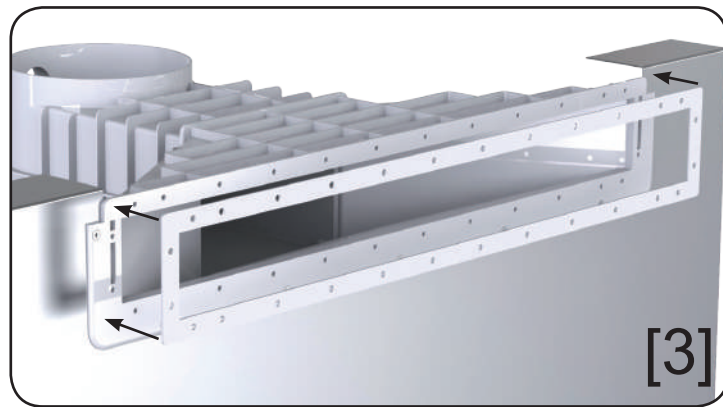

Zet een vlakke pakking met de adhesieve zijde op de behuizing.

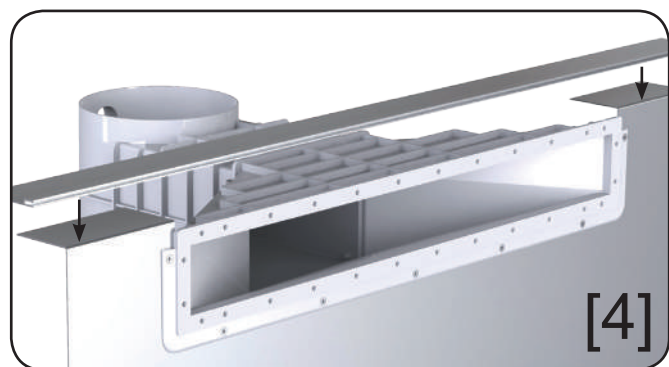

Bevestig de liner-beugel op de bovenzijde van de wand. Versterken van een metalen bus op bazen die worden vastgesteld.

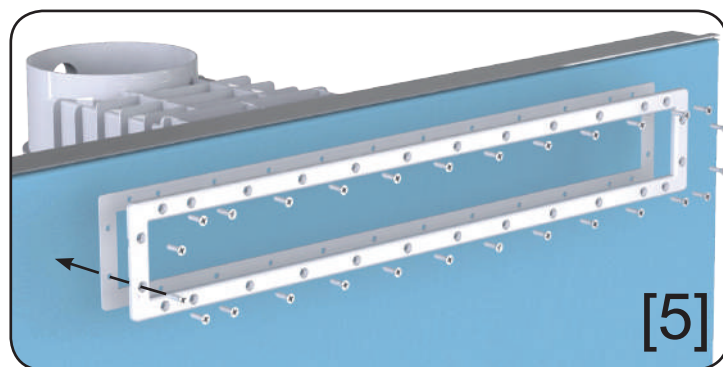

Wanneer de liner eenmaal geplaatst is, zet de tweede vlakke pakking met de adhesieve zijde op de flens. Plaats de flens op de liner om overeen te komen met de gaten en schroef vervolgens alle schroeven vast.

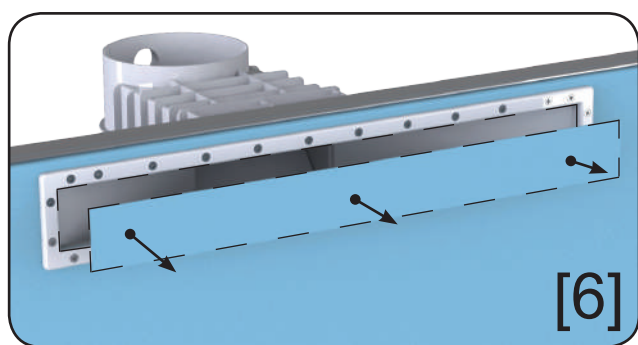

Zaag de liner met behulp van een cutter op de binnenzijde van de flens. Til het einde van de liner op.

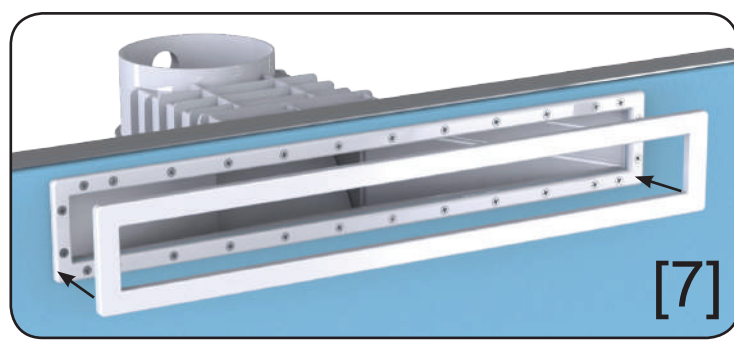

Klem het schroefdeksel op de flens

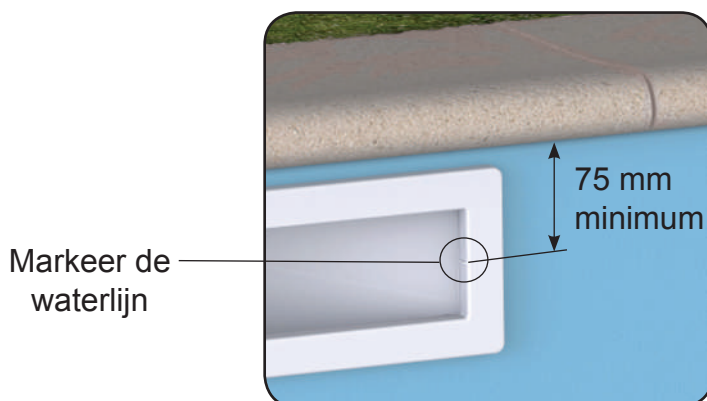

## PLAATS OP DE BETONNEN MUUR, BETON LINER OF HET CASCO

De voorgaande plaatsingsmethodes zijn identiek op traditionele modellen.

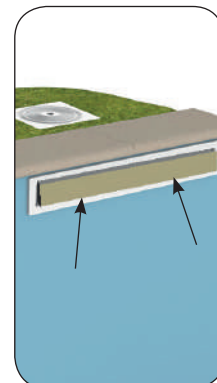
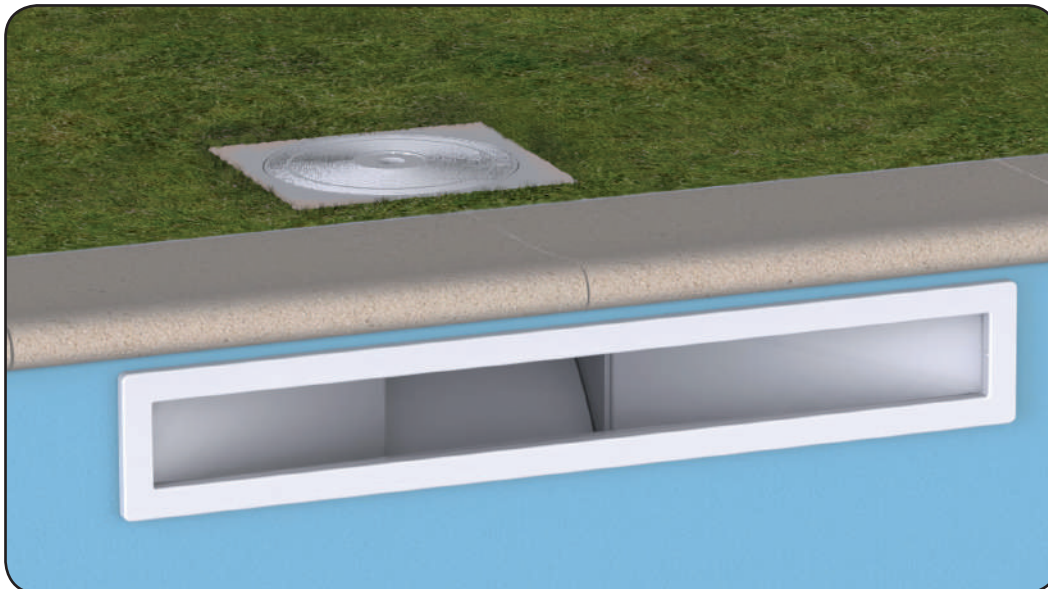

zet het schuimblok op voordat u beton giet

### ONDERDELEN

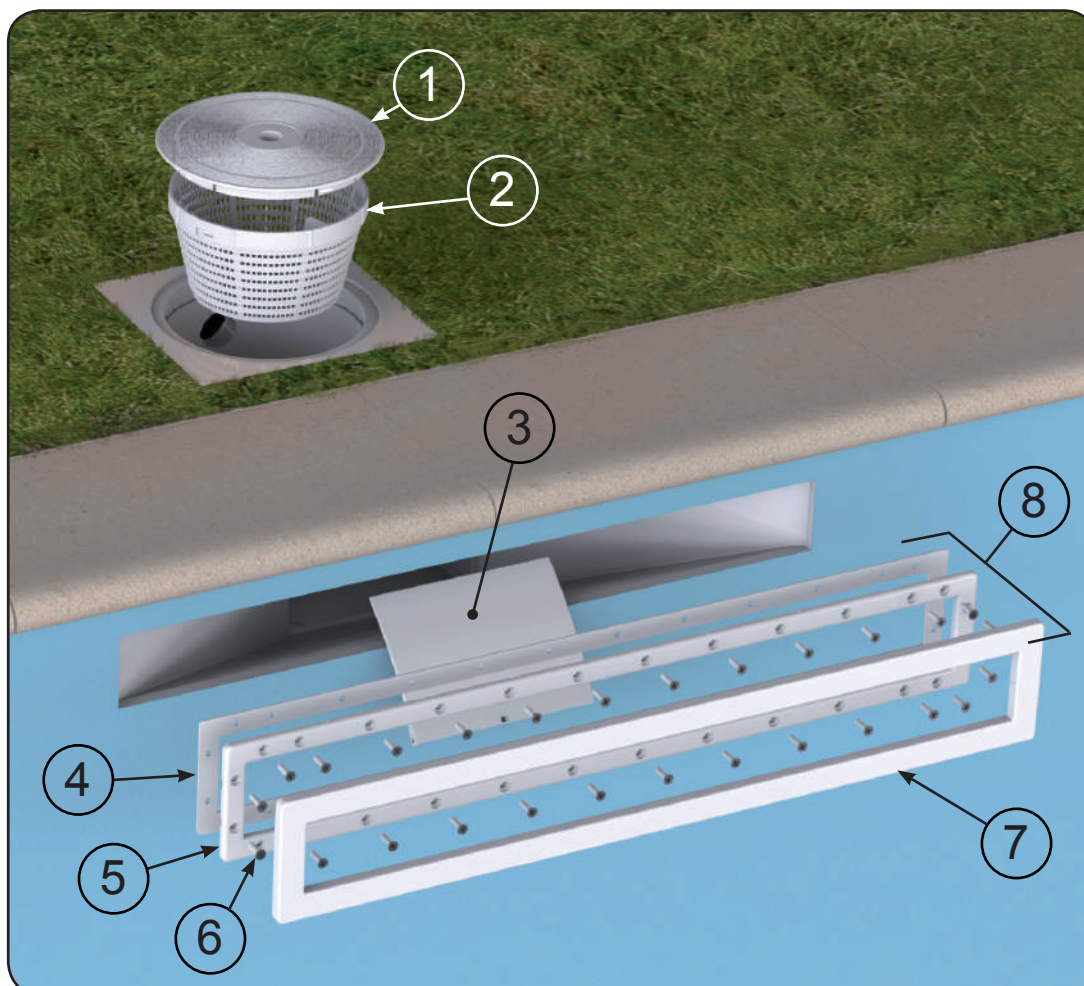

N°	LINER	BETON	CASCO
1	DEKSEL	DEKSEL	DEKSEL
2	MAND	MAND	MAND
3	LUIK	LUIK	LUIK
4	VLAKKE PAKKING A800	-	VLAKKE PAKKING A800
5	FLENS A800	-	FLENS A800
6	ZAK SCHROEVEN LINER A800	-	ZAK SCHROEVEN LINER A800
7	SCHROEFDEKSEL	-	SCHROEFDEKSEL
8	KIT LINER A800	-	KIT LINER A800



## AVISO DE MONTAGEM SKIMMER A800

Agradecemos a sua escolha de um equipamento WELTICO e convidamo-lo a ler cuidadosamente este aviso que lhe permitirá obter total satisfação.

- A instalação deste skimmer requer a intervenção de pessoas qualificadas.



**IMPORTANTE:** este aviso contém informações de importância vital sobre as medidas de segurança a adoptar no momento de instalação e colocação em serviço. Consequentemente, é indispensável que o instalador e o utilizador leiam cuidadosamente estas instruções antes de iniciarem a montagem.

Este aviso está também disponível em formato PDF e EPUB em [www.weltico.com](http://www.weltico.com) no item SKIMMER.

### DURANTE A RECEÇÃO DO MATERIALEL

Deve receber um conjunto de 2 embalagens:

- Uma embalagem que contém o assassino e os seus acessórios.
- Uma embalagem que contém a peça SKIMMER e os seus acessórios.

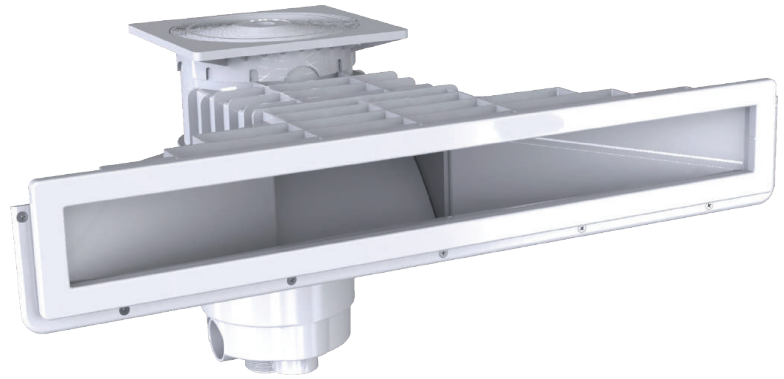

### ESPECIFICAÇÕES TÉCNICAS:

#### VERSÃO: PAINEL / FORRO / CIMENTO / REVESTIMENTO

- Feito de ABS
- Overflow Ø 50mm no exterior
- Saídas:
  - Ø50mm no interior (x2)
  - 1"1/2 dentro ou 2" fora

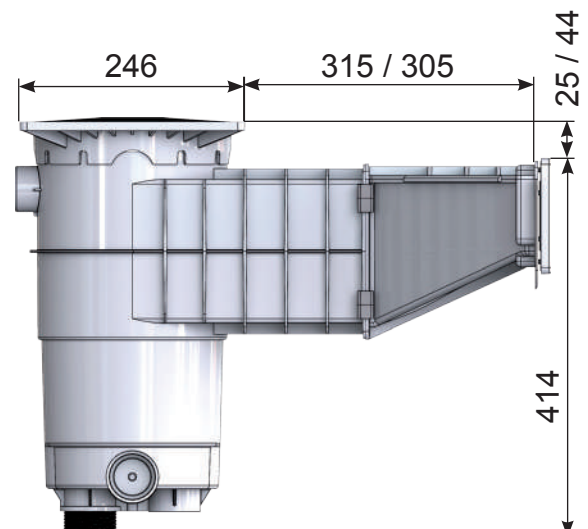
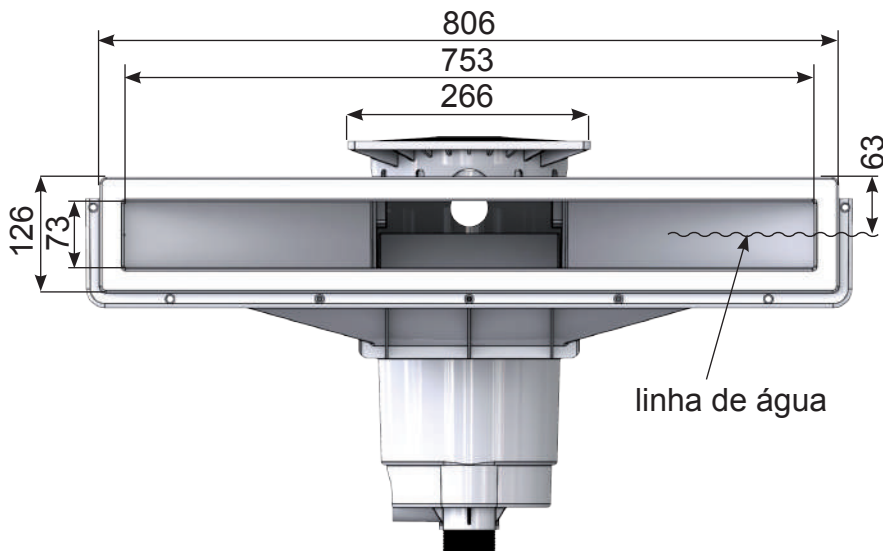



## MONTAGEM

As duas peças podem ser montadas previamente ou depois da colocação na parede.

 **ATENÇÃO:** Assim que as duas peças sejam coladas com a cola fornecida, é praticamente impossível separá-la passado cerca de 1/2 hora.

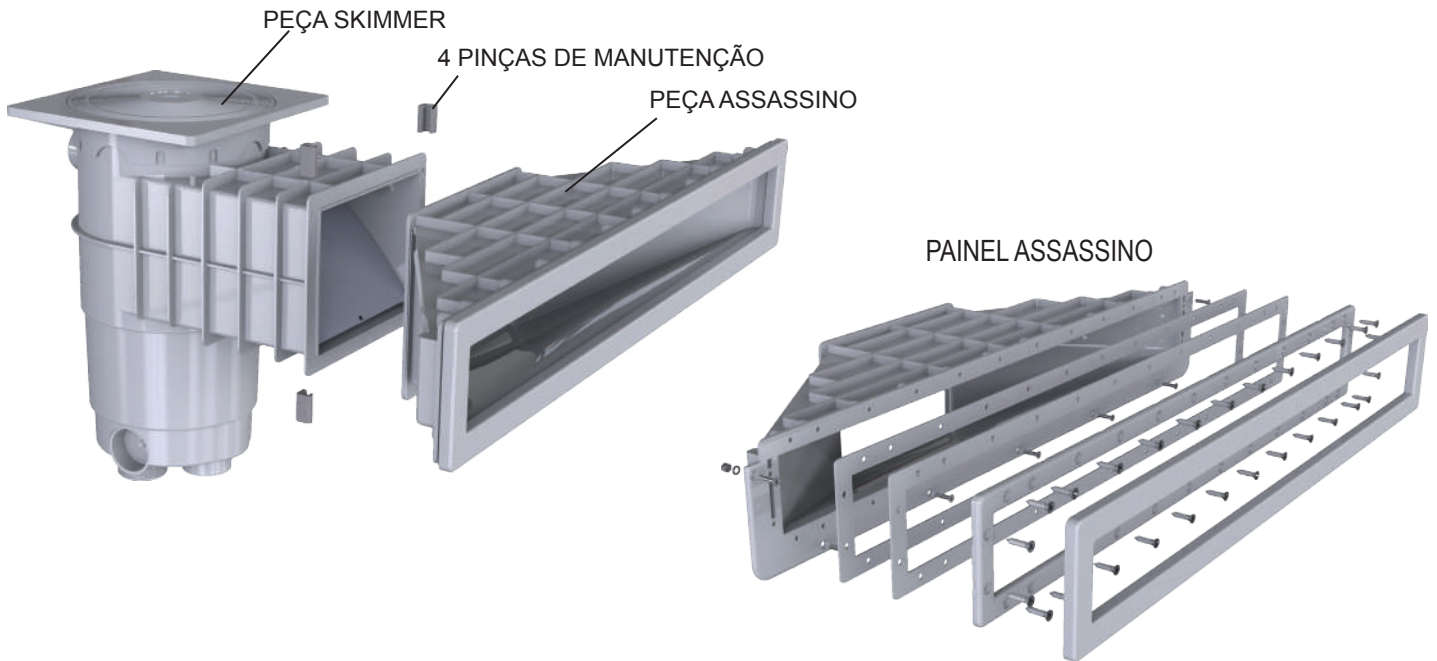

ASSASSINO CIMENTO

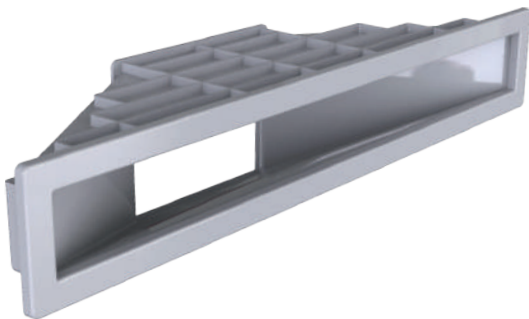

ASSASSINO FORRO DE CIMENTO / REVESTIMENTO

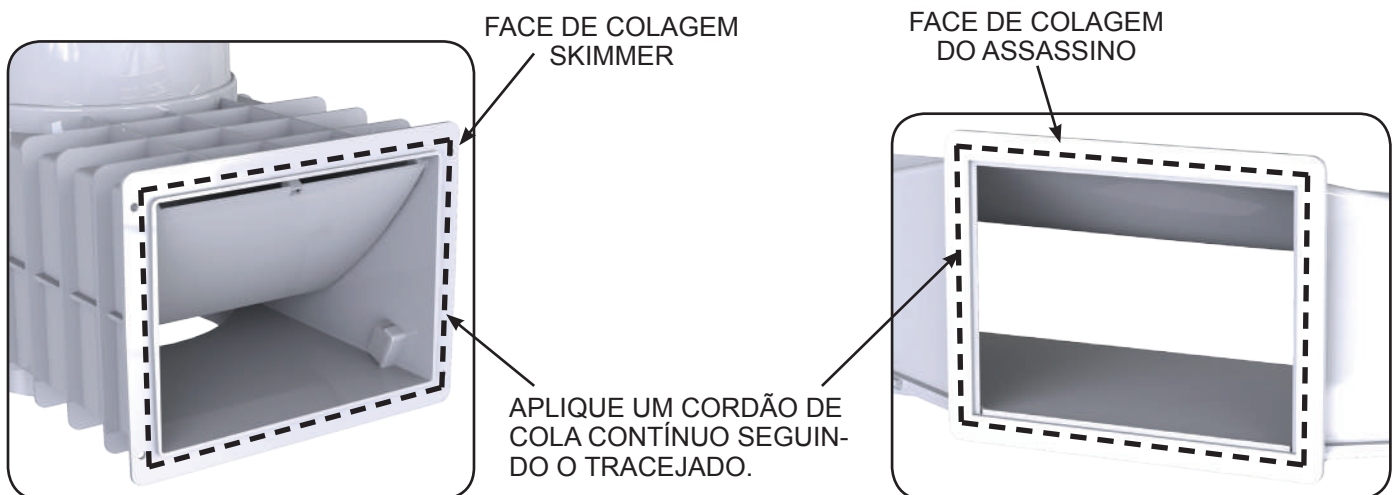
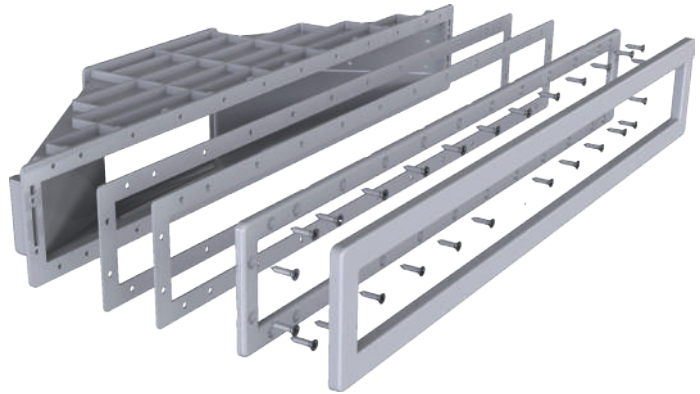

Faça deslizar as 4 pinças para manter as 2 peças entre elas.

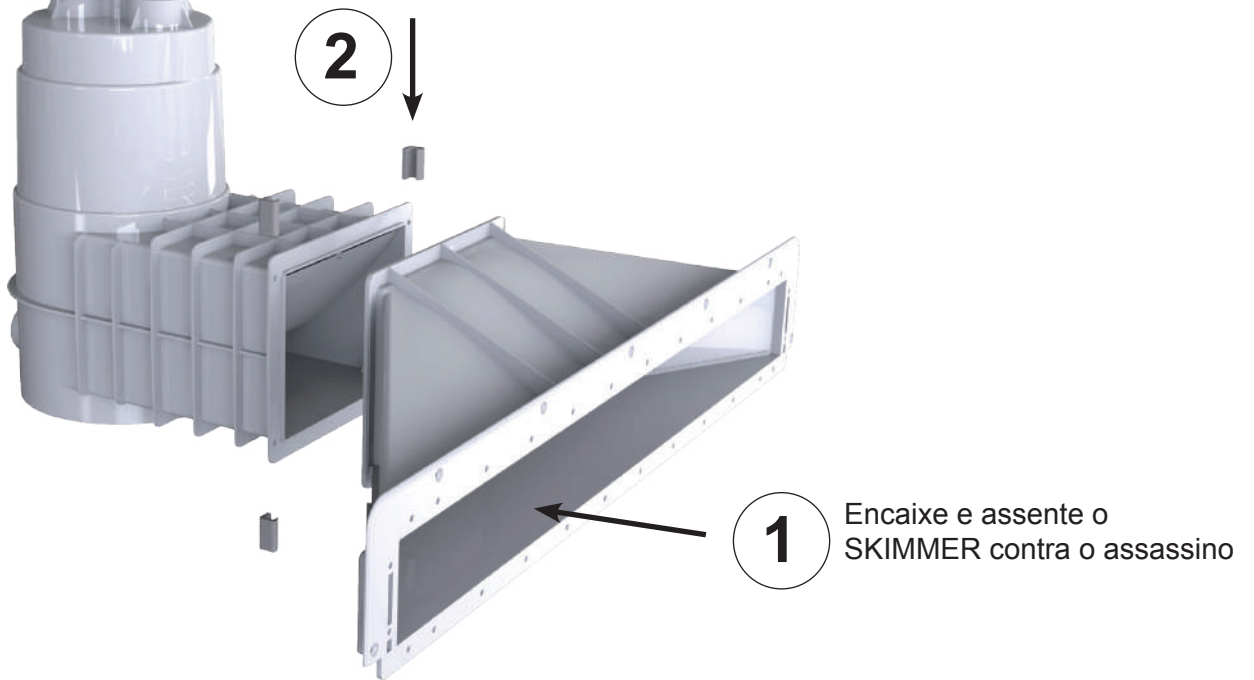

### COLOQUE NO LUGAR A PAREDE PAINEL

A versão de painel requer um corte especial para a sua fixação.



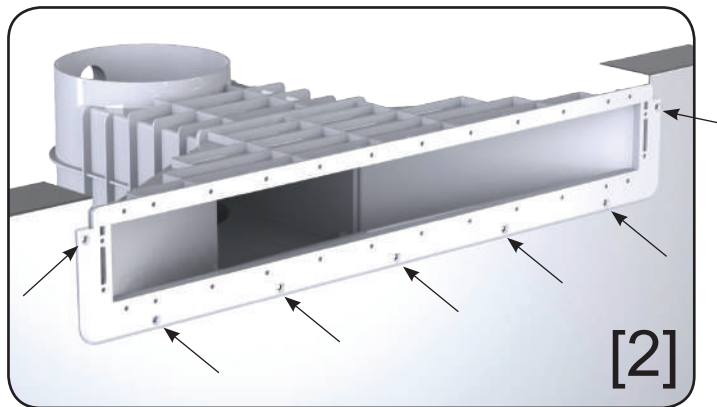

Coloque o conjunto ou o assassino em posição na parede como ilustrado abaixo. Perfure nos locais indicados pelas setas para passagem dos parafusos. Aparafuse com os parafusos fornecidos.

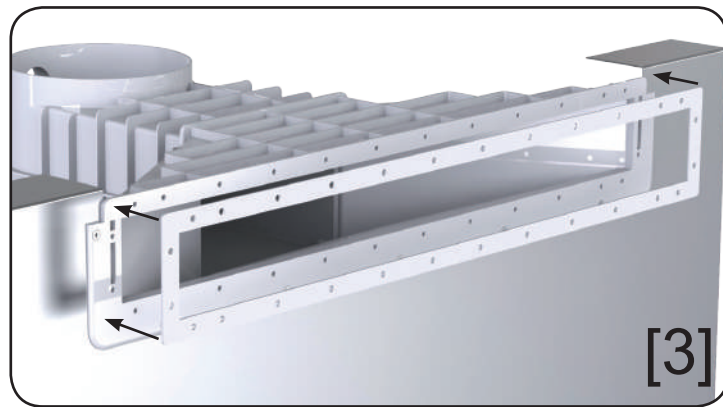

Coloque umas juntas planas com superfície adesiva sobre o assassino.

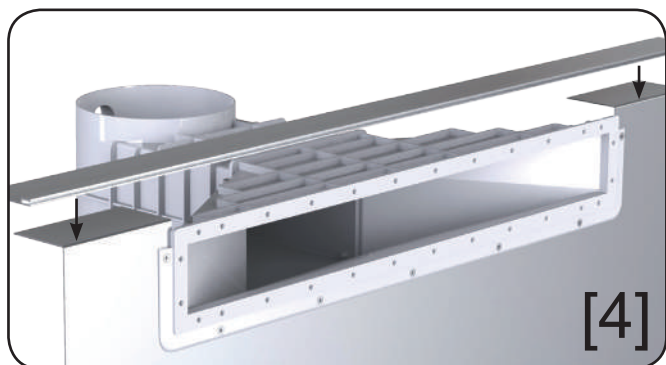

Instale o encaixe do forro por baixo da parede. Reforçar uma bucha de metal para ser fixado em bosses prestados.

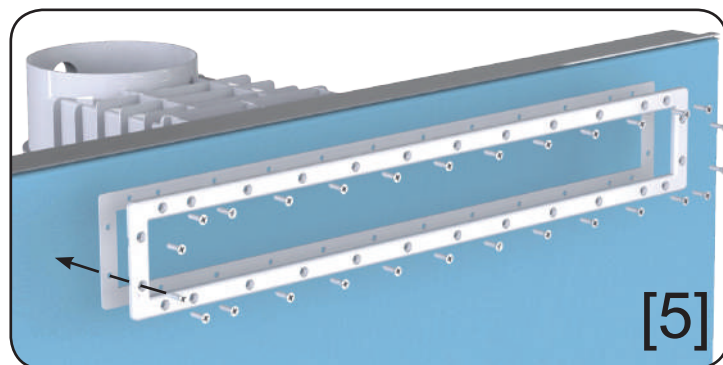

Assim que o forro esteja colocado aplique a segunda junta plana com superfície adesiva na flange de ligação. Posicione a flange sobre o forro a fim de fazer corresponder com os orifícios e depois aperte todos os parafusos.

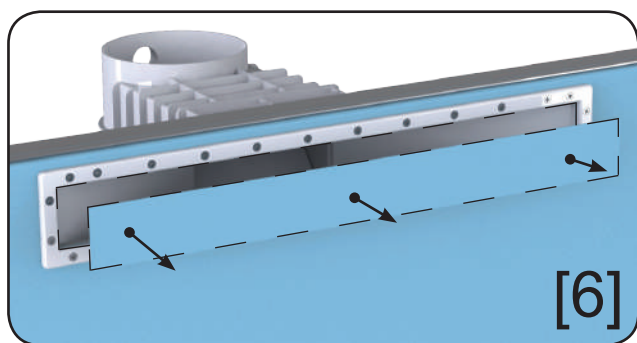

Com a ajuda de uma faca, corte o forro no interior da flange. Levante a ponta do forro.

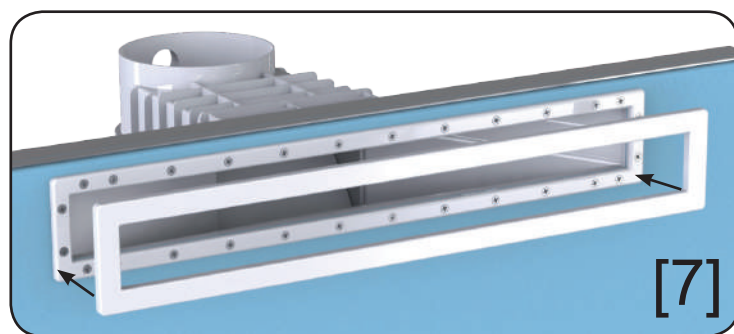

Prenda a tampa do parafuso sobre a flange

Marque um ponto de referência da linha de água

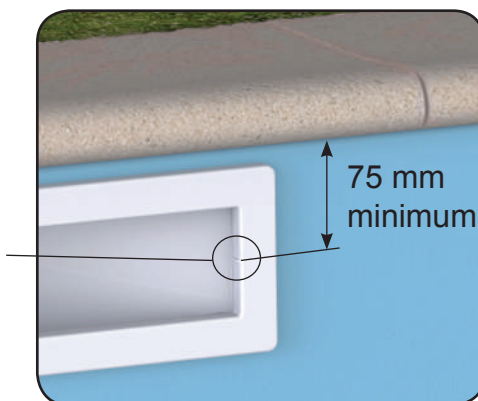



## COLOCAÇÃO NA PAREDE DE CIMENTO, FORRO DE CIMENTO OU REVESTIMENTO

Os procedimentos de instalação no local são idênticos aos modelos tradicionais.

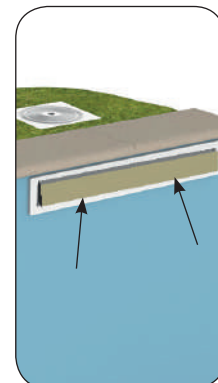
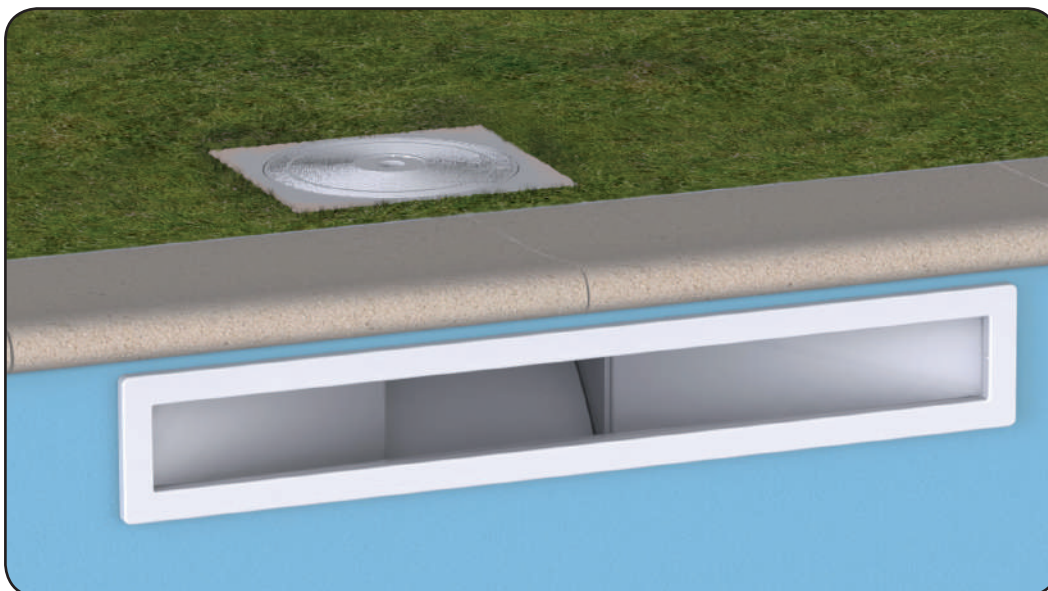

 Configure o bloco de espuma antes de derramar o concreto.

### PEÇAS SOLTAS

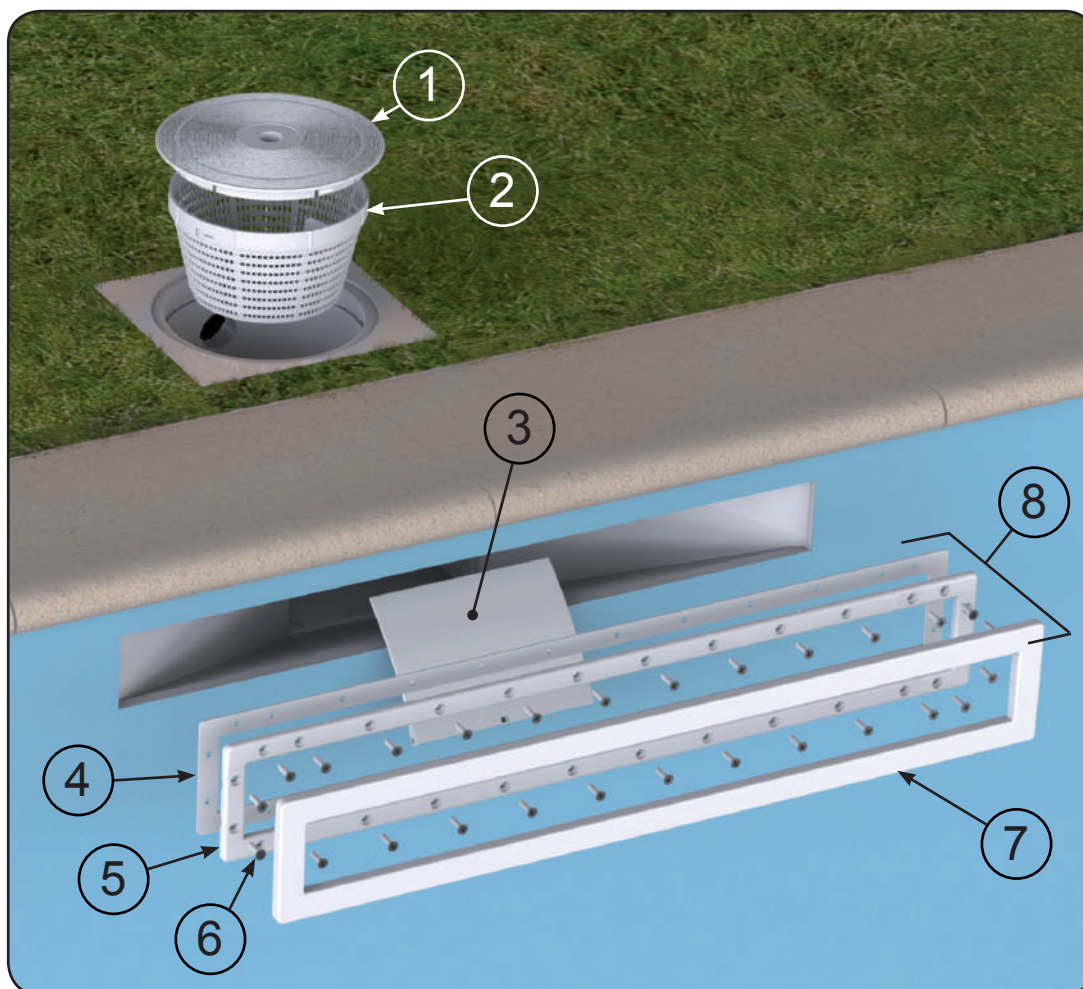

Nº	LINER	CIMENTO	REVESTIMENTO
1	TAMPA	TAMPA	TAMPA
2	CESTO	CESTO	CESTO
3	CERCA	CERCA	CERCA
4	JUNTA PLANA A800	-	JUNTA PLANA A800
5	FLANGE A800	-	FLANGE A800
6	SACO DE PARAFUSOS PARA LINER A800	-	SACO DE PARAFUSOS PARA LINER A800
7	TAMPA DE PARAFUSOS A800	-	CTAMPA DE PARAFUSOS A800
8	KIT LINER A800	-	KIT LINER A800



